

Stability of Pythagorean Mean Functional Equation

P.Narasimman¹, K. Ravi², Sandra Pinelas³

¹ Department of Mathematics, Thiruvalluvar University College of Arts and Science, Gajalnaickanpatti, Tirupattur-635 901, TamilNadu, India.

² Department of Mathematics, Sacred Heart College, Tirupattur-635 601, TamilNadu, India

³ Academia Militar, Departamento de Ciências Exactas e Naturais, Av. Conde Castro Guimarães, 2720-113 Amadora, Portugal

Abstracts:

In this paper, authors introduce a new Pythagorean mean functional equation which relates the three classical Pythagorean mean and investigate its generalized Hyers-Ulam stability. Also, Motivated by the work of Roman Ger [7], we deal with the general solution of Pythagorean means functional equation. We also provide counter-examples for singular cases. Very specially in this paper we illustrate the geometrical interpretation and application of new introduced Pythagorean mean functional equation.

Key words and phrases: Pythagorean Means, Arithmetic mean, Geometric mean and Harmonic mean, Generalized Hyers-Ulam stability.

2010 Mathematics Subject Classification: 39B52, 39B62, 39B72, 39B82.

1. Introduction

There is a legend that one day when Pythagoras (c.500 BCE) was passing a blacksmith's shop, he heard harmonious music ringing from the hammers. When he enquired, he was told that the weights of the hammers were 6, 8, 9, and 12 pounds. These ratios produce a fundamental and its fourth, fifth and octave. This was evidence that the elegance of mathematics is manifested in the harmony of nature.

Returning to music, these ratios are indeed a foundation of music as noted by Archytus of Tarentum (c.350 BCE): There are three 'means' in music: one is the arithmetic, the second is the geometric and the third is the subcontrary, which they call 'harmonic'.

The arithmetic mean is when there are three terms showing successively the same excess: the second exceeds the third by the same amount as the first exceeds the second. In this proportion, the ratio of the larger number is less, that of the smaller numbers greater.

The geometric mean is when the second is to the third as the first is to the second; in this, the greater numbers have the same ratio as the smaller numbers.

The subcontrary, which we call harmonic, is as follows: by whatever part of itself the first term exceeds the second, the middle term exceeds the third by the same part of the third. In this proportion, the ratio of the larger numbers is large and of the lower numbers less [15].

In order to understand these descriptions, it is necessary to realize that for Greeks, a mean for two numbers $B > A$, was a third number C satisfying $B > C > A$ and a further property. The above description of the arithmetic mean, geometric mean and harmonic mean states that

$$B - C = C - A \text{ (this is "the same numerical amount" referred to by Plato),}$$

$$\frac{C}{A} = \frac{B}{C} \text{ (this is "the same fraction of the extremes" referred to by Plato),}$$

$$\frac{B - C}{B} = \frac{C - A}{A}$$

respectively and the above algebraic manipulation recharacterizes is as follows

$$C = \frac{A + B}{2}, C = \sqrt{AB}, C = \frac{2AB}{A + B}$$

the arithmetic mean, geometric mean and harmonic mean respectively.

Definition 1.1 Pythagorean Means:[4] In Mathematics, the three classical Pythagorean means are the arithmetic mean(A), the Geometric mean(G), and the harmonic mean(H). They are defined by

$$A(x_1, x_2, \dots, x_n) = \frac{1}{n}(x_1 + \dots + x_n)$$

$$G(x_1, x_2, \dots, x_n) = \sqrt[n]{x_1 + \dots + x_n}$$

$$H(x_1, x_2, \dots, x_n) = \frac{n}{\frac{1}{x_1} + \dots + \frac{1}{x_n}}$$

The stability problem of functional equations originates from the fundamental question: When is it true that a mathematical object satisfying a certain property approximately must be close to an object satisfying the property exactly?

In connection with the above question, in 1940, S.M. Ulam [24] raised a question concerning the stability of homomorphisms. Let G be a group and let G' be a metric group with $d(.,.)$. Given $\varepsilon > 0$ does there exist a $\delta > 0$ such that if a function $f : G \rightarrow G'$ satisfies the inequality $d(f(xy), f(x)f(y)) < \delta$ for all $x, y \in G$, then there is a homomorphism $H : G \rightarrow G'$ with $d(f(x), H(x))$ for all $x \in G$?

The first partial solution to Ulam's question was given by D.H. Hyers [9]. He considered the case of approximately additive mappings $f : E \rightarrow E'$ where E and E' are Banach spaces and f satisfies Hyers inequality

$$\|f(x+y) - f(x) - f(y)\| \leq \delta$$

for all $x, y \in E$, it was shown that the limit

$$a(x) = \lim_{n \rightarrow \infty} \frac{f(2^n x)}{2^n}$$

exists for all $x \in E$ and that $a : E \rightarrow E'$ is the unique additive mapping satisfying

$$\|f(x) - a(x)\| \leq \varepsilon.$$

Moreover, it was proved that if $f(tx)$ is continuous in t for each fixed $x \in E$, then a is linear. In this case, the Cauchy additive functional equation $f(x+y) = f(x) + f(y)$ is said to satisfy the Hyers-Ulam stability.

In 1978, Th.M. Rassias [23] provided a generalized version of the theorem of Hyers which permitted the Cauchy difference to become unbounded. He proved the following theorem.

Theorem 1.2 [Th.M.Rassias] If a function $f : E \rightarrow E'$ between Banach spaces satisfies the inequality

$$\|f(x+y) - f(x) - f(y)\| \leq \theta(\|x\|^p + \|y\|^p) \quad (1.1)$$

for some $\theta \geq 0$, $0 \leq p < 1$ and for all $x, y \in E$, then there exists a unique additive function $a : E \rightarrow E'$ such that

$$\|f(x) - a(x)\| \leq \frac{2\theta}{2-2^p} \|x\|^p \quad (1.2)$$

for all $x \in E$. Moreover, if $f(tx)$ is continuous in t for each fixed $x \in E$, then a is linear.

A particular case of Th.M. Rassias' theorem regarding the Hyers-Ulam stability of the additive mappings was proved by T. Aoki [1]. The theorem of Rassias was later extended to all $p \neq 1$ and generalized by many mathematicians (see [2, 3, 5, 8, 10, 18, 19, 20]). The phenomenon that was introduced and proved by Th.M. Rassias is called the Hyers-Ulam-Rassias stability. The Hyers-Ulam-Rassias stability for various functional equations have been extensively investigated by numerous authors; one can refer to ([11, 12, 13, 14, 16, 17]). In 1994, a generalization of the Th.M. Rassias' theorem was obtained by P.G. Ćirić [6], who replaced the bound $\theta(\|x\|^p + \|y\|^p)$ by a general control function $\varphi(x, y)$.

In 1982-1989, J.M.Rassias [18, 19] replaced the sum appeared in right hand side of the equation (1.1) by the product of powers of norms. This stability is called Ulam-Gavruta-Rassias stability involving a product of different powers of norms. Infact, he proved the following theorem.

Theorem 1.3 [J.M.Rassias] Let $f : E_1 \rightarrow E_2$ be a mapping from a normed vector space E_1 into Banach space E_2 subject to the inequality

$$\|f(x+y) - f(x) - f(y)\| \leq \varepsilon \|x\|^p \|y\|^p \tag{1.3}$$

for all $x, y \in E_1$, where ε and p are constants with $\varepsilon > 0$ and $0 \leq p < \frac{1}{2}$. Then the limit

$$L(x) = \lim_{n \rightarrow \infty} \frac{f(2^n x)}{2^n} \tag{1.4}$$

exist for all $x \in E_1$ and $L : E_1 \rightarrow E_2$ is the unique additive mapping which satisfies

$$\|f(x) - L(x)\| \leq \frac{\varepsilon}{2 - 2^{2p}} \|x\|^{2p} \tag{1.5}$$

for all $x \in E_1$. If $p > \frac{1}{2}$ the inequality (1.3) holds for $x, y \in E_1$ and the limit

$$A(x) = \lim_{n \rightarrow \infty} 2^n f\left(\frac{x}{2^n}\right) \tag{1.6}$$

exist for all $x \in E_1$ and $A : E_1 \rightarrow E_2$ is the unique additive mapping which satisfies

$$\|f(x) - A(x)\| \leq \frac{\varepsilon}{2^{2p} - 2} \|x\|^{2p} \tag{1.7}$$

for all $x \in E_1$.

Very recently, J. M. Rassias replaced the sum appeared in right hand side of the equation (1.1) by the mixed product of powers of norms in [21]. The investigation of stability of functional equation involving with the mixed product of power norms is known as Hyers-Ulam-J.M.Rassias stability.

In 2010, K. Ravi and B.V. Senthil Kumar [22] investigated some results on Ulam -Gavruta-Rassias stability of the functional equation

$$r(x+y) = \frac{r(x)r(y)}{r(x)+r(y)}. \tag{1.8}$$

It was proved that the reciprocal function $r(x) = \frac{c}{x}$ is a solution of the functional equation (1.8).

Definition 1.4 Pythagorean mean functional equation: Pythagorean mean functional equation is an functional equation which arises from the relations between the three Pythagorean means of arithmetic mean, geometric mean and harmonic mean.

With the motivation of the Pythagorean means, that is; arithmetic mean, geometric mean, harmonic mean and its relations. In this paper, authors arrive the Pythagorean means functional equation of the form

$$f\left(\sqrt{x^2 + y^2}\right) = \frac{f(x)f(y)}{f(x)+f(y)}, \quad x, y \in (0, \infty) \tag{1.9}$$

with $f(x) = \frac{c}{x^2}$ and very specially in this paper we illustrate the geometrical interpretation in Section 2. In Section 3, Motivated by the work of Roman Ger [7] we deal with the solution of Pythagorean mean functional equation (1.9). In Section

4, we investigate the generalized Hyers-Ulam stability of equation (1.9) also we provide counter-examples for singular cases. In Section 5, we investigate the application of new introduced Pythagorean mean functional equation.

2. Geometrical Interpretation of Equation (1.9)

Consider the circle centre A and the tangent to the circle from the point M touching the circle at the point G with $PM = a$, $QM = b$ and $a > b > 0$.

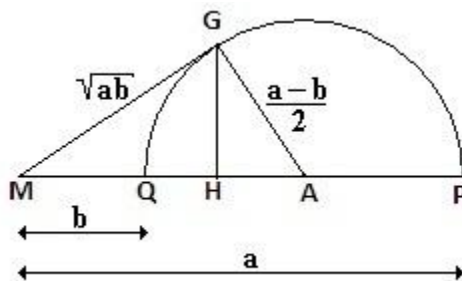

We can work out the radius of the circle and show the length AM is $\frac{(a+b)}{2}$ be the arithmetic mean of a and b . Using Pythagoras' theorem we can get the length GM is \sqrt{ab} be the geometric mean of a and b . Using the fact that the triangles AGM and GHM are similar we can get HM is $\frac{2ab}{(a+b)}$ be the harmonic mean of a and b . From the definition of Pythagorean means and from the diagram, one can shows that the harmonic mean is related to the arithmetic mean and the geometric mean by $HM = \frac{GM^2}{AM}$. So

$$GM = \sqrt{AM \cdot HM} \tag{2.1}$$

meaning the two numbers geometric mean equals the geometric mean of their arithmetic and harmonic means. By rewriting the equation (2.1), we get

$$\sqrt{\frac{HM}{AM}} \cdot GM = HM. \tag{2.2}$$

In the above diagram, if we take $a = \frac{1}{x^2}$ and $b = \frac{1}{y^2}$, and applying in (2.2) we get

$$\frac{1}{x^2 + y^2} = \frac{\frac{1}{x^2} \frac{1}{y^2}}{\frac{1}{x^2} + \frac{1}{y^2}}. \tag{2.3}$$

Comparing this result (2.3) with (1.9), we obtain $f(x) = \frac{1}{x^2}$. This proves that the Pythagorean mean functional equation (1.9) holds good in the above geometric construction.

Throughout this paper, let us assume X be a linear space and Y be a Banach space. For the sake of convenience, let us denote

$$Df(x, y) = f\left(\sqrt{x^2 + y^2}\right) - \frac{f(x)f(y)}{f(x) + f(y)}$$

for all $x, y \in X$.

3. General Solution of the Functional Equation (1.9)

In this section, motivated by the work of Roman Ger [7], we present the general solution of the Pythagorean mean functional equation in the simplest case and also we give the differentiable solution of (1.9). The following Theorem gives the solution of (1.9) in the simplest case.

Theorem 3.1 Simplest case: *The only nonzero solution $f : (0, \infty) \rightarrow \mathbf{R}$, admitting a finite limit of the quotient*

$$\frac{f(x)}{\frac{1}{x^2}} \text{ at zero, of the equation(1.9) is of the form } f(x) = \frac{c}{x^2}, (x, y) \in (0, \infty) \times (0, \infty)$$

Proof. Put $y = x$ in (1.9) to get the equality

$$f(\sqrt{2}x) = \frac{1}{2} f(x)$$

for all $x \in (0, \infty)$. Setting

$$g(x) = \frac{f(x)}{\frac{1}{x}},$$

for all $x \in (0, \infty)$, we have

$$\lim_{x \rightarrow 0^+} \frac{g(x)}{\frac{1}{x}} =: c \in \mathbf{R}$$

as well as

$$g(\sqrt{2}x) = \frac{1}{\sqrt{2}} g(x),$$

for all $x \in (0, \infty)$. By a simple induction, for every positive integer n , we also obtain the equalities

$$g\left(\frac{x}{(\sqrt{2})^n}\right) = (\sqrt{2})^n g(x),$$

for all $x \in (0, \infty)$, whence, finally,

$$\frac{g(x)}{\frac{1}{x}} = \frac{(\sqrt{2})^n g(x)}{(\sqrt{2})^n \frac{1}{x}} = \frac{g\left(\frac{1}{(\sqrt{2})^n} x\right)}{\frac{1}{x}} \rightarrow c \text{ as } n \rightarrow \infty.$$

Consequently, for every $x \in (0, \infty)$, we get

$$f(x) = \frac{1}{x} g(x) = \frac{1}{x} \frac{1}{x} c = \frac{c}{x^2},$$

as claimed, because clearly c cannot vanish since, otherwise, we would have $f = 0$.

The following Theorem gives the differentiable solution of the Pythagorean mean functional equation (1.9).

Theorem 3.2 Differentiable Solution: Let $f : (0, \infty) \rightarrow \mathbf{R}$ be continuously differentiable functions with nowhere vanishing derivatives f' . Then f yields a solution to the functional equation (1.9) if and only if there exists nonzero real constants c such that $f(x) = \frac{c}{x^2}, x \in (0, \infty)$.

Proof. Differentiate equation (1.9) with respect to x on both side, we obtain

$$f'(\sqrt{x^2 + y^2}) \frac{x}{\sqrt{x^2 + y^2}} = \frac{f'(x)(f(y))^2}{(f(x) + f(y))^2} \tag{3.1}$$

for all $x, y \in (0, \infty) \times (0, \infty)$. Since on setting $y = x$ in (1.9) we deduce that

$$f(\sqrt{2}x) = \frac{1}{2} f(x) \tag{3.2}$$

and, a fortiori,

$$f'(\sqrt{2}x) = \frac{1}{2\sqrt{2}} f'(x) \tag{3.3}$$

for all $x \in (0, \infty)$. Putting $y = \sqrt{2}x$ in (3.1) and using equations (3.2) and (3.3), we arrive

$$f'(\sqrt{3}x) = \frac{1}{3\sqrt{3}} f'(x) \tag{3.4}$$

for all $x \in (0, \infty)$. The equation (3.3) and (3.4) gives

$$f'((\sqrt{2})^n (\sqrt{3})^m) = \frac{1}{2^n (\sqrt{2})^n} \frac{1}{3^m (\sqrt{3})^m} f'(x)$$

for all $x \in (0, \infty)$. for all integers n, m and due to the continuity of the map f' , we derive its linearity

$$f'(\lambda) = f'(1) \frac{2}{(\lambda)^3}$$

for $\lambda \in (0, \infty)$. Therefore, there exists real numbers $c \neq 0, d$, such that $f(x) = \frac{c}{x^2} + d$ for $x \in (0, \infty)$. Note that

we have to have $d = 0$ because of the equality $f(\sqrt{2}x) = \frac{1}{2} f(x)$ valid for all positive x . Which completes the proof.

4. Generalized Hyers- Ulam Stability of Equation (1.9)

Theorem 4.1 Let $f : X \rightarrow Y$ be a mapping satisfying

$$\|Df(x, y)\| \leq \varphi(x, y) \tag{4.1}$$

where $\varphi : X^2 \rightarrow Y$ is a function such that

$$\psi(x) = 2 \sum_{i=0}^{\infty} 2^i \varphi(2^{\frac{i}{2}} x, 2^{\frac{i}{2}} x) \tag{4.2}$$

with the condition

$$\lim_{n \rightarrow \infty} 2^n \varphi(2^{\frac{n}{2}} x, 2^{\frac{n}{2}} x) = 0 \tag{4.3}$$

for all $x \in X$. Then there exists a unique reciprocal-quadratic mapping $r : X \rightarrow Y$ which satisfies (1.9) and the inequality

$$\|r(x) - f(x)\| \leq \psi(x) \tag{4.4}$$

for all $x \in X$.

Proof. Replacing y by x in (4.1) and multiplying by 2 , we get

$$\|2f(\sqrt{2}x) - f(x)\| \leq 2\varphi(x, x) \tag{4.5}$$

for all $x \in X$. Now, replacing x by $\sqrt{2}x$ in (5), multiplying by 2 and summing the resulting inequality with (5), we obtain

$$\|2^2 f(2x) - f(x)\| \leq 2 \sum_{i=0}^1 2^i \varphi(2^{\frac{i}{2}}x, 2^{\frac{i}{2}}x)$$

for all $x \in X$. Proceeding further and using induction on a positive integer n , we arrive

$$\begin{aligned} \|2^n f(2^{\frac{n}{2}}x) - f(x)\| &\leq 2 \sum_{i=0}^{n-1} 2^i \varphi(2^{\frac{i}{2}}x, 2^{\frac{i}{2}}x) \\ &\leq 2 \sum_{i=0}^{\infty} 2^i \varphi(2^{\frac{i}{2}}x, 2^{\frac{i}{2}}x) \end{aligned} \tag{4.6}$$

for all $x \in X$. In order to prove the convergence of the sequence $\{2^n f(2^{\frac{n}{2}}x)\}$, replace x by $2^{\frac{n}{2}}x$ in (4.6) and multiply by 2^n , we find that for $n > m > 0$

$$\begin{aligned} \left\| 2^n f\left(2^{\frac{n}{2}}x\right) - 2^m f\left(2^{\frac{m}{2}}x\right) \right\| &= 2^n \left\| f\left(2^{\frac{n}{2}}x\right) - 2^{m-n} f\left(2^{\frac{m-n}{2}}2^{\frac{n}{2}}x\right) \right\| \\ &\leq 2 \sum_{i=0}^{\infty} 2^{n+i} \phi\left(2^{\frac{n+i}{2}}x, 2^{\frac{n+i}{2}}x\right). \end{aligned} \tag{4.7}$$

Allow $n \rightarrow \infty$ and using (4.3), the right hand side of the inequality (4.7) tends to 0 . Thus the sequence $\{2^n f(2^{\frac{n}{2}}x)\}$ is a Cauchy sequence. Allowing $n \rightarrow \infty$ in (4.6), we arrive (4.4). To show that r satisfies (1.9), setting

$r(x) = \lim_{n \rightarrow \infty} 2^n f(2^{\frac{n}{2}}x)$, replacing (x, y) by $(2^{\frac{n}{2}}x, 2^{\frac{n}{2}}y)$ in (4.1) and multiplying by 2^n , we obtain

$$\|2^n D(2^{\frac{n}{2}}x, 2^{\frac{n}{2}}y)\| \leq 2^n \varphi(2^{\frac{n}{2}}x, 2^{\frac{n}{2}}y). \tag{4.8}$$

Allowing $n \rightarrow \infty$ in (4.8), we see that r satisfies (1.9) for all $x, y \in X$. To prove r is a unique reciprocal-quadratic mapping satisfying (1.9). Let $R : X \rightarrow Y$ be another reciprocal-quadratic mapping which satisfies (1.9) and the inequality

(4.4). Clearly $R(2^{\frac{n}{2}}x) = 2^{-n}R(x)$, $r(2^{\frac{n}{2}}x) = 2^{-n}r(x)$ and using (4.4), we arrive

$$\begin{aligned} \|R(x) - r(x)\| &= 2^n \|R(2^{\frac{n}{2}}x) - r(2^{\frac{n}{2}}x)\| \\ &\leq 2^n (\|R(2^{\frac{n}{2}}x) - f(2^{\frac{n}{2}}x)\| + \|f(2^{\frac{n}{2}}x) - r(2^{\frac{n}{2}}x)\|) \\ &\leq 4 \sum_{i=0}^{\infty} 2^{n+i} \varphi(2^{\frac{n+i}{2}}x, 2^{\frac{n+i}{2}}x) \end{aligned} \tag{4.9}$$

for all $x \in X$. Allowing $n \rightarrow \infty$ in (4.9) and using (4.3), we find that r is unique. This completes the proof of Theorem 4.1.

Theorem 4.2 Let $f : X \rightarrow Y$ be a mapping satisfying (4.1), where $\varphi : X^2 \rightarrow Y$ is a function such that

$$\psi(x) = 2 \sum_{i=0}^{\infty} 2^{-(i+1)} \phi(2^{-\frac{(i+1)}{2}} x, 2^{-\frac{(i+1)}{2}} x) \tag{4.10}$$

with the condition

$$\lim_{n \rightarrow \infty} 2^{-n} \phi(2^{-\frac{n-1}{2}} x, 2^{-\frac{n-1}{2}} x) = 0 \tag{4.11}$$

for all $x \in X$. Then there exists a unique reciprocal mapping $r : X \rightarrow Y$ which satisfies (1.9) and the inequality

$$\|r(x) - f(x)\| \leq \psi(x) \tag{4.12}$$

for all $x \in X$.

Proof. The proof is obtained by replacing (x, y) by $(\frac{x}{\sqrt{2}}, \frac{x}{\sqrt{2}})$ in (4.1) and proceeding further by similar arguments as in Theorem 4.1.

The following Corollaries are the immediate consequences of Theorem 4.1 and 4.2 which gives the Hyers-Ulam-Rassias stability, Ulam-Gavruta-Rassias stability and Hyers-Ulam-J.M.Rassias stability of the functional equation (1.9).

Corollary 4.3 For any fixed $c_1 \geq 0$ and $p < -2$ or $p > -2$, if $f : X \rightarrow Y$ satisfies

$$\|Df(x, y)\| \leq c_1 (\|x\|^p + \|y\|^p) \tag{4.13}$$

for all $x, y \in X$, then there exists a unique reciprocal mapping $r : X \rightarrow Y$ such that

$$\|r(x) - f(x)\| \leq \begin{cases} \frac{4c_1}{1-2^{\frac{2+p}{2}}} \|x\|^p & \text{for } p < -2 \\ \frac{4c_1}{2^{\frac{2+p}{2}} - 1} \|x\|^p & \text{for } p > -2 \end{cases}$$

for all $x \in X$.

Proof. If we choose $\varphi(x, y) = c_1 (\|x\|^p + \|y\|^p)$, for all $x, y \in X$, then by Theorem 4.1, we arrive

$$\|r(x) - f(x)\| \leq \frac{4c_1}{1-2^{\frac{2+p}{2}}} \|x\|^p, \text{ for all } x \in X \text{ and } p < -2$$

and using Theorem 4.2, we arrive

$$\|r(x) - f(x)\| \leq \frac{4c_1}{2^{\frac{2+p}{2}} - 1} \|x\|^p, \text{ for all } x \in X \text{ and } p > -2.$$

Now we will provide an example to illustrate that the functional equation (1.9) is not stable for $p = -2$ in Corollary 4.3.

Example 4.4 Let $\phi : \mathbb{R} \rightarrow \mathbb{R}$ be a function defined by

$$\phi(x) = \begin{cases} \frac{a}{x^2}, & \text{if } x \in (1, \infty) \\ a, & \text{otherwise} \end{cases}$$

where $a > 0$ is a constant and a function $f : \mathbb{R} \rightarrow \mathbb{R}$ by

$$f(x) = \sum_{n=0}^{\infty} \frac{\phi(2^{-n}x)}{2^{2n}} \quad \text{for all } x \in \mathbb{R}.$$

Then f satisfies the functional inequality

$$\|Df(x, y)\| \leq 8a \times \left(\left| \frac{1}{x^2} \right| + \left| \frac{1}{y^2} \right| \right) \tag{4.14}$$

for all $x, y \in \mathbb{R}$. Then there do not exist a reciprocal mapping $r : \mathbb{R} \rightarrow \mathbb{R}$ and a constant $\beta > 0$ such that

$$|f(x) - r(x)| \leq \beta \left| \frac{1}{x^2} \right| \quad \text{for all } x \in \mathbb{R}. \tag{4.15}$$

Proof. Now

$$|f(x)| \leq \sum_{n=0}^{\infty} \frac{|\phi(2^{-n}x)|}{|2^{2n}|} = \sum_{n=0}^{\infty} \frac{a}{2^{2n}} = \frac{4}{3}a.$$

Therefore we see that f is bounded. We are going to prove that f satisfies (4.14).

If $\left| \frac{1}{x^2} \right| + \left| \frac{1}{y^2} \right| \geq 1$ then the left hand side of (4.14) is less than $2a$. Now suppose that $0 < \left| \frac{1}{x^2} \right| + \left| \frac{1}{y^2} \right| < 1$.

Then there exist a positive integer r such that

$$\frac{1}{2^{2(r+1)}} \leq \left| \frac{1}{x^2} \right| + \left| \frac{1}{y^2} \right| < \frac{1}{2^{2r}}, \tag{4.16}$$

so that

$$2^{2r} \frac{1}{x^2} < 1, 2^{2r} \frac{1}{y^2} < 1 \tag{4.17}$$

$$\text{or } \frac{x^2}{2^{2r}} > 1, \frac{y^2}{2^{2r}} > 1$$

$$\text{or } \frac{x}{2^r} > 1, \frac{y}{2^r} > 1$$

consequently $\frac{x}{2^{r-1}} > 2 > 1, \frac{y}{2^{r-1}} > 2 > 1$. And again from (4.17), we get

$$\frac{x^2}{2^{2(r-1)}} > 2^2 > 1, \frac{y^2}{2^{2(r-1)}} > 2^2 > 1$$

consequently $\frac{1}{2^{2(r-1)}}(x^2 + y^2) > 1, \frac{1}{2^{r-1}}\sqrt{x^2 + y^2} > 1$. Hence, we get

$$\frac{x}{2^{r-1}} > 1, \frac{y}{2^{r-1}} > 1, \frac{1}{2^{r-1}}\sqrt{x^2 + y^2} > 1.$$

Therefore for each $n = 0, 1, \dots, r - 1$, we have

$$\frac{x}{2^n} > 1, \frac{y}{2^n} > 1, \frac{1}{2^n} \sqrt{x^2 + y^2} > 1,$$

and

$$\phi\left(\frac{1}{2^n}(\sqrt{x^2 + y^2})\right) - \frac{\phi\left(\frac{x}{2^n}\right)\phi\left(\frac{y}{2^n}\right)}{\phi\left(\frac{x}{2^n}\right) + \phi\left(\frac{y}{2^n}\right)} = 0$$

for $n = 0, 1, \dots, r - 1$. From the definition of f and (4.16), we obtain that

$$\begin{aligned} & \left| f\left(\sqrt{x^2 + y^2}\right) - \frac{f(x)f(y)}{f(x) + f(y)} \right| \\ & \leq \sum_{n=0}^{\infty} \frac{1}{2^{2n}} \left| \phi\left(\frac{1}{2^n}(\sqrt{x^2 + y^2})\right) - \frac{\phi\left(\frac{x}{2^n}\right)\phi\left(\frac{y}{2^n}\right)}{\phi\left(\frac{x}{2^n}\right) + \phi\left(\frac{y}{2^n}\right)} \right| \\ & \leq \sum_{n=r}^{\infty} \frac{1}{2^{2n}} \left| \phi\left(\frac{1}{2^n}(\sqrt{x^2 + y^2})\right) + \frac{\phi\left(\frac{x}{2^n}\right)\phi\left(\frac{y}{2^n}\right)}{\phi\left(\frac{x}{2^n}\right) + \phi\left(\frac{y}{2^n}\right)} \right| \\ & \leq \sum_{n=r}^{\infty} \frac{1}{2^{2n}} \left(\frac{3a}{2}\right) = 2a \times \frac{1}{2^{2r}} \\ & = 2a \times 2^2 \left(\left|\frac{1}{x^2}\right| + \left|\frac{1}{y^2}\right| \right) \\ & = 8a \times \left(\left|\frac{1}{x^2}\right| + \left|\frac{1}{y^2}\right| \right). \end{aligned}$$

Thus f satisfies (4.14) for all $x, y \in \mathbf{R}$ with $0 < \left|\frac{1}{x^2}\right| + \left|\frac{1}{y^2}\right| < 1$.

We claim that the reciprocal functional equation (1.9) is not stable for $p = -2$ in Corollary 4.3. Suppose on the contrary, there exist a reciprocal mapping $r : \mathbf{R} \rightarrow \mathbf{R}$ and a constant $\beta > 0$ satisfying (4.15). There, we have

$$|f(x)| \leq (\beta + 1) \left|\frac{1}{x^2}\right|. \tag{4.18}$$

But we can choose a positive integer m with $ma > \beta + 1$.

If $x \in (1, 2^{m-1})$, then $2^{-n}x \in (1, \infty)$ for all $n = 0, 1, \dots, m - 1$. For this x , we get

$$f(x) = \sum_{n=0}^{\infty} \frac{\phi(2^{-n}x)}{2^{2n}} \geq \sum_{n=0}^{m-1} \frac{(2^{-n}x)^2}{2^{2n}} = m \frac{a}{x^2} > (\beta + 1) \frac{1}{x^2}$$

which contradicts (4.18). Therefore the reciprocal functional equation (1.9) is not stable in sense of Ulam, Hyers and Rassias if $p = -2$, assumed in the inequality (4.13).

Corollary 4.5 Let $f : X \rightarrow Y$ be a mapping and there exists p such that $p < -2$ or $p > -2$. If there exists $c_2 \geq 0$ such that

$$\|Df(x, y)\| \leq c_2 (\|x\|^{\frac{p}{2}} \|y\|^{\frac{p}{2}})$$

for all $x, y \in X$, then there exists a unique reciprocal mapping $r : X \rightarrow Y$ satisfying the functional equation (1.9) and

$$\|r(x) - f(x)\| \leq \begin{cases} \frac{2c_2}{1-2^{\frac{2+p}{2}}} \|x\|^p & \text{for } p < -2 \\ \frac{2c_2}{2^{\frac{2+p}{2}}-1} \|x\|^p & \text{for } p > -2 \end{cases}$$

for all $x \in X$.

Proof. Considering $\phi(x, y) = c_2 (\|x\|^{\frac{p}{2}} \|y\|^{\frac{p}{2}})$, for all $x, y \in X$, then by Theorem 4.1, we arrive

$$\|r(x) - f(x)\| \leq \frac{2c_2}{1-2^{\frac{2+p}{2}}} \|x\|^p, \text{ for all } x \in X \text{ and } p < -2$$

and using Theorem 4.2, we arrive

$$\|r(x) - f(x)\| \leq \frac{2c_2}{2^{\frac{2+p}{2}}-1} \|x\|^p, \text{ for all } x \in X \text{ and } p > -2.$$

Corollary 4.6 Let $c_3 > 0$ and $\alpha < -1$ or $\alpha > -1$ be real numbers, and $f : X \rightarrow Y$ be a mapping satisfying the functional inequality

$$\|Df(x, y)\| \leq c_3 \left\{ \|x\|^{2\alpha} + \|y\|^{2\alpha} + (\|x\|^\alpha \|y\|^\alpha) \right\}$$

for all $x, y \in X$. Then there exists a unique reciprocal mapping $r : X \rightarrow Y$ satisfying the functional equation (1.9) and

$$\|r(x) - f(x)\| \leq \begin{cases} \frac{6c_3}{1-2^{\alpha+1}} \|x\|^{2\alpha} & \text{for } \alpha < -1 \\ \frac{6c_3}{2^{\alpha+1}-1} \|x\|^{2\alpha} & \text{for } \alpha > -1 \end{cases}$$

for all $x \in X$.

Proof. Choosing $\phi(x, y) = c_3 \left\{ \|x\|^{2\alpha} + \|y\|^{2\alpha} + (\|x\|^\alpha \|y\|^\alpha) \right\}$, for all $x, y \in X$, then by Theorem 4.1, we arrive

$$\|r(x) - f(x)\| \leq \frac{6c_3}{1-2^{\alpha+1}} \|x\|^{2\alpha}, \text{ for all } x \in X \text{ and } \alpha < -1$$

and using Theorem 4.2, we arrive

$$\|r(x) - f(x)\| \leq \frac{6c_3}{2^{\alpha+1} - 1} \|x\|^{2\alpha}, \text{ for all } x \in X \text{ and } \alpha > -1.$$

Now we will provide an example to illustrate that the functional equation (1.9) is not stable for $p = -1$ in Corollary 4.6.

Example 4.7 Let $\phi : \mathbb{R} \rightarrow \mathbb{R}$ be a function defined by

$$\phi(x) = \begin{cases} \frac{k}{x^2}, & \text{if } x \in (1, \infty) \\ k, & \text{otherwise} \end{cases}$$

where $k > 0$ is a constant and a function $f : \mathbb{R} \rightarrow \mathbb{R}$ by

$$f(x) = \sum_{n=0}^{\infty} \frac{\phi(2^{-n}x)}{2^{2n}} \quad \text{for all } x \in \mathbb{R}.$$

Then f satisfies the functional inequality

$$\|Df(x, y)\| \leq 8k \times \left(\left| \frac{1}{x^2} \right| + \left| \frac{1}{y^2} \right| + |x|^{-1} |y|^{-1} \right) \tag{4.19}$$

for all $x, y \in \mathbb{R}$. Then there do not exist a reciprocal mapping $r : \mathbb{R} \rightarrow \mathbb{R}$ and a constant $\beta > 0$ such that

$$|f(x) - r(x)| \leq \beta \left| \frac{1}{x^2} \right| \quad \text{for all } x \in \mathbb{R}. \tag{4.20}$$

Proof. Now

$$|f(x)| \leq \sum_{n=0}^{\infty} \frac{|\phi(2^{-n}x)|}{|2^{2n}|} = \sum_{n=0}^{\infty} \frac{k}{2^{2n}} = \frac{4}{3}k.$$

Therefore we see that f is bounded. We are going to prove that f satisfies (4.19).

If $\left| \frac{1}{x^2} \right| + \left| \frac{1}{y^2} \right| + |x|^{-1} |y|^{-1} \geq 1$ then the left hand side of (4.19) is less than $2a$. Now suppose that

$0 < \left| \frac{1}{x^2} \right| + \left| \frac{1}{y^2} \right| + |x|^{-1} |y|^{-1} < 1$. Then there exist a positive integer r such that

$$\frac{1}{2^{2(r+1)}} \leq \left| \frac{1}{x^2} \right| + \left| \frac{1}{y^2} \right| + |x|^{-1} |y|^{-1} < \frac{1}{2^{2r}}, \tag{4.21}$$

and the rest of the proof is same as the proof of Example 4.4.

5.Application of Functional Equation (1.9)

The Parallel Circuit and the Functional Equation (1.9): A parallel circuit has more than one resistor and gets its name from having multiple paths to move along. Also one can know that the following rule apply to a parallel circuit.

The inverse of the total resistance of the circuit is equal to the sum of the inverses of the individual resistances, that is

$$\frac{1}{R_T} = \frac{1}{R_1} + \frac{1}{R_2} + \frac{1}{R_3} + \dots \tag{5.1}$$

For only two resistors, the unreciprocated expression (5.1) simplifies to

$$R_T = \frac{R_1 R_2}{R_1 + R_2} \tag{5.2}$$

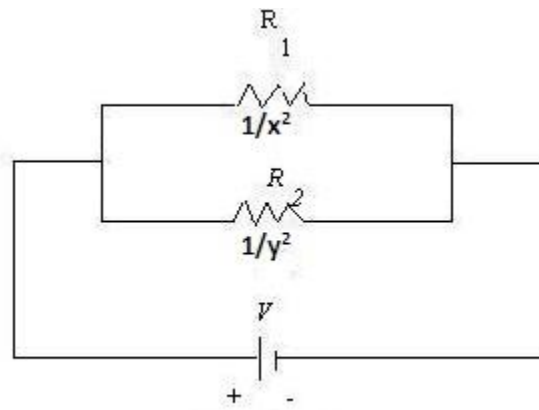

Refer to the above Figure. If we take $R_1 = \frac{1}{x^2}, R_2 = \frac{1}{y^2}$, we get

$$R_T = \frac{\frac{1}{x^2} \frac{1}{y^2}}{\frac{1}{x^2} + \frac{1}{y^2}} \tag{5.3}$$

Since electrical conductance G is reciprocal to resistance, therefore total conductance of the above circuit is $G_T = x^2 + y^2$. Now from the equation (5.3), we get

$$\frac{1}{G_T} = \frac{\frac{1}{x^2} \frac{1}{y^2}}{\frac{1}{x^2} + \frac{1}{y^2}}$$

$$\frac{1}{x^2 + y^2} = \frac{\frac{1}{x^2} \frac{1}{y^2}}{\frac{1}{x^2} + \frac{1}{y^2}} \tag{5.4}$$

One can easily identify the equation (5.4) is our main functional equation (1.9) with $f(x) = \frac{c}{x^2}$. Hence the functional equation (1.9) holds good in the above circuit.

6. Conclusion

In this paper authors mainly achieved a new Pythagorean mean functional equation corresponding to the relation between three classical Pythagorean means and obtained the general solution of Pythagorean means functional equation from the motivated work of Roman Ger [7].

Also, authors investigated its generalized Hyers-Ulam stability and also provided counter-examples for singular cases. Very specially in this paper we illustrated the geometrical interpretation and applications of our introduced Pythagorean means functional equation in connection with the Parallel Circuit.

References

- [1] **T. Aoki**, *On the stability of the linear transformation in Banach spaces*, J. Math.Soc. Japan, 2(1950), 64-66.
- [2] **P.W. Cholewa**, *Remarks on the stability of functional equations*, Aequationes Math., 27 (1984), 76-86.
- [3] **S. Czerwik**, *Functional Equations and Inequalities in Several Variables*, World Scientific Publishing Co., Singapore, New Jersey, London, 2002.
- [4] **H.Eves**, *Means Appearing in Geometric Figures* Math. Mag. 76 (2003), pp 292-294.
- [5] **G.L. Forti**, *Hyers-Ulam stability of functional equations in several variables*, Aequationes Math., 50(1995), 143-190.
- [6] **P. Gavruta**, *A generalization of the Hyers-Ulam-Rassias Stability of approximately additive mapping*, J. Math. Anal. Appl., 184 (1994), 431 - 436.
- [7] **Roman Ger**, *Abstract Pythagorean theorem and corresponding functional equations* Tatra Mt. Math. Publ. 55 (2013), 67-75.
- [8] **A.Grabiec**, *The generalized Hyers-Ulam stability of a class of functional equations*, Publ. Math.Debrecen 48(1996), 217-235.
- [9] **D.H. Hyers**, *On the stability of the linear functional equation*, Proc. Nat. Acad. Sci. U.S.A. 27 (1941), 222-224.
- [10] **G. Isac and Th.M. Rassias**, *Stability of ψ – additive mappings: applications to nonlinear analysis*, Int. J. Math. Math. Sci., 19(2)(1996), 219-228.
- [11] **S.M. Jung**, *A fixed point approach to the stability of a Volterra integral equation*, Fixed Point Theory and Applications, 2007(2007), Article ID 57064, 9 pages, doi:10.1155/2007/57064.
- [12] **S.M. Jung**, *A fixed point approach to the stability of the equation $f(x+y) = \frac{f(x)f(y)}{f(x)+f(y)}$* , The Australian Journal of Mathematical Analysis and Applications, Vol.6(8)(2009), 1-6.
- [13] **Y.S. Jung and I.S. Chang**, *The stability of a cubic type functional equation with the fixed point alternative*, J.Math.Anal.Appl.306(2)(2005), 752-760.
- [14] **Pl. Kannappan**, *Quadratic functional equation and inner product spaces*, Results Math., 27(1995), 368-372.
- [15] **Kathleen Freeman**, *Ancilla to the Pre-Socratic Philosophers*, Sacred-texts.com; <http://www.sacred-texts.com/cla/app/app42.htm>, 1948.
- [16] **P. Nakmahachalasint**, *Hyers-Ulam-Rassias and Ulam-Gavruta-Rassias stabilities of an Additive Functional Equation in Several variables*, Internat.J.Math. and Math.Sc.,(IJMMS) Article ID 13437, 6 pages, 2007.
- [17] **C. Park**, *Generalized Hyers-Ulam Stability of quadratic functional equations:A fixed point approach*, Fixed Point Theory and Applications, Vol.2008(2008), Article ID 493751, 9 pages, doi:10.1155/2008/493751.
- [18] **J.M. Rassias**, *On approximation of approximately linear mappings by linear mappings*, J. Funct. Anal. 46 (1982), 126-130.
- [19] **J.M. Rassias**, *On approximation of approximately linear mappings by linear mappings*, Bull. Sci. Math. 108 (1984), 445-446.
- [20] **J.M. Rassias**, *Solution of a problem of Ulam*, J. Approx.Theory, 57 (1989), 268-273.
- [21] **K. Ravi, M. Arunkumar, J.M. Rassias**, *On the Ulam stability for a or- thogonally general Euler-Lagrange type functional equation*, International Journal of Mathematics sciences, Int. J. Math. Stat., 3, No. A08 (2008), 36-46.
- [22] **K. Ravi and B.V. Senthil Kumar**, *Ulam-Gavruta-Rassias stability of Rassias Reciprocal functional equation*, Global Journal of App. Math. and Math. Sci. 3(1-2), Jan-Dec 2010, 57-79.
- [23] **Th.M. Rassias**, *On the stability of the linear mapping in Banach spaces*, Proc.Amer.Math. Soc. 72 (1978), 297-300.
- [24] **S.M. Ulam**, *A collection of mathematical problems*, Interscience Publishers, Inc.New York, 1960.