

Current Differential Line Protection Using a Pattern Recognition Method

V. Fernão Pires*, C. Fortunato**

* Escola Superior Tecnologia Setúbal / Instituto Politécnico Setúbal

** EDP – Energias de Portugal, Lisboa

E-mail of contact author: vitor.pires@estsetubal.ips.pt
Portugal

Keywords: Current differential protection, pattern recognition, line protection, digital relay.

Abstract

This paper presents a new approach to a numerical current differential protection for the transmission lines. The current differential algorithm uses a pattern recognition method. First the acquired current signals are transformed into “*dqo*” components by applying the Park transformation. The transformed currents will originate typical patterns according the fault type. Using a pattern recognition algorithm the different faulty conditions are identified. Several tests under different fault conditions were performed. The obtained results allow verifying the effectiveness of the proposed approach.

1 Introduction

The role of the protection power system is to ensure that, in the event of a fault, the faulted element must be disconnected from the power system. There are many different relay schemes for the protection of the several power system equipments. Among them, distance relay is one of the most used protection system for the transmission lines [1-4]. However, this relay has some disadvantages such as, to know the line parameters. Current differential relays have been used for the efficient protection of generators, power transformers and buses [5-8]. They detect differential current or the sum of current flowing into these equipments. One of the advantages of this protection scheme is that the discrimination between internal and external faults is easily achieved, allowing to improve the speed clearing times.

Due to the characteristics of the differential relay, this protection type has been applied to the transmission lines [9-11]. The line current differential protection scheme is based on the same principle of the transformer differential protection. In fact, the obtained currents at the ends of a transmission line are vectorially summed. Due to this, this protection is considered with high sensitivity, high speed and with simultaneous tripping of both line terminals. Another advantage of this protection, is that this relay is unaffected by external effects such as faults, loads and power swings. However, in this protection scheme it is required a communication link. In this way, the line currents measured at the ends of a transmission line must be sampled to become current packets to transfer through the high speed communication link for the process of differential current. In generally, the communication link used for this purposed are communication cable, power line carrier, microwave and fibber optics [12]

The current differential line protection allows improving speed clearing times for faults occurring at any point on a transmission line. However, since this protection is dependent of the communication between relays, problems such as sampling misalignment and communications channel delay make accurate current comparison difficult to achieve. To overcome the sampling misalignment problem and communications channel delay, current differential relay based on synchronized current measurement using Global Positioning system Satellite (GPS) is normally used [12]. However, GPS has some problems. In fact, GPS is a sophisticated system that may suffer interruption, and it is not controlled by power system utilities. In this way a method based on a synchronous rotating frame has been proposed [13], which however does not allow to identify the faulty phase.

In this paper a new approach for a current differential relay of a transmission line protection is presented, using the transformed currents in “*dqo*” components by applying the Park transformation. Through the use of the differential transformed currents, typical patterns in the “*dqo*” can be obtained. This allows to identify the faulty type that can occur in a transmission line. Since this method is based on the analysis of the typical patterns, problems such as sampling misalignment and time delay of the

communication channel can be attenuated. Several test results allow to validate the proposed approach.

2 Proposed line current differential protection

Current differential line protection is based on the comparison of the current flowing into a line to the current flowing out of the same line. Fig. 1 shows the transmission line current differential relaying scheme. This system protection consists in two relays operating independently and linked by a digital communication channel.

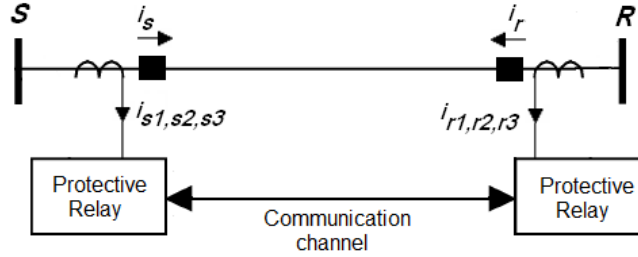

Fig. 1. Transmission line current differential relaying scheme.

In classical schemes, each relay samples its analogue input currents, via an analog-to-digital converter and exchange these samples between them. In the proposed system, instead of using the classical approach where a simple comparison between currents is used, it is applied a pattern recognition approach to the acquired currents.

First, the acquired current signals are transmitted to the other line terminal and, at the same time, transformed into “ dqo ” components by applying the Park Transform (1) (2), where the time varying angle θ represents the angular position of the reference frame which is rotating at constant speed in synchronism with the three-phase AC voltages.

$$\begin{bmatrix} i_{d s} \\ i_{q s} \\ i_{o s} \end{bmatrix} = P \begin{bmatrix} i_{s1} \\ i_{s2} \\ i_{s3} \end{bmatrix} \quad \text{and} \quad \begin{bmatrix} i_{d r} \\ i_{q r} \\ i_{o r} \end{bmatrix} = P \begin{bmatrix} i_{r1} \\ i_{r2} \\ i_{r3} \end{bmatrix} \quad (1)$$

$$P = \frac{2}{3} \begin{bmatrix} \cos \theta & \cos\left(\theta - \frac{2\pi}{3}\right) & \cos\left(\theta + \frac{2\pi}{3}\right) \\ \sin \theta & \sin\left(\theta - \frac{2\pi}{3}\right) & \sin\left(\theta + \frac{2\pi}{3}\right) \\ \frac{1}{2} & \frac{1}{2} & \frac{1}{2} \end{bmatrix} \quad (2)$$

The current data received from the communication channel is also transformed into “ dqo ” components. Using the transformed currents of both sides of the transmission line, the differential algorithm will be obtained. Fig. 2 shows a block diagram of the proposed approach.

The differential currents in “ dqo ” components can be represented in the planes “ dq ” and “ do ”. Analysing the pattern figures in the planes “ dq ” and “ do ”, it is possible to verify that, in normal situations, it is obtained a single point in these planes. For a phase to phase fault it is obtained a circle in the “ dq ” plane and a single point in the “ do ” plane. These patterns for a phase-to-earth fault are a circle in the “ dq ” plane and an eight shape in the “ do ” plane.

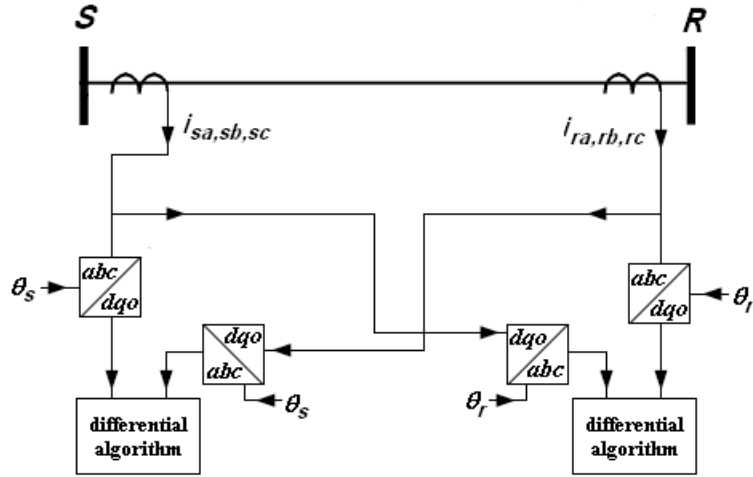

Fig. 2. Block diagram of the proposed approach.

To identify the faulty operation it will be used the circumference radius – rc – and the distance between the mass center and the origin – dcm (Fig. 3). These are obtained by equations (3) and (4) where N is the number of current samples in one cycle.

$$dcm = \sqrt{\left(\frac{\sum_{n=1}^N i_{d_n}}{N}\right)^2 + \left(\frac{\sum_{n=1}^N i_{q_n}}{N}\right)^2} \quad (3)$$

$$rc = \sqrt{\left(\frac{\sum_{n=1}^N i_{d_n}}{N} - i_{d_k}\right)^2 + \left(\frac{\sum_{n=1}^N i_{q_n}}{N} - i_{q_k}\right)^2} \quad (4)$$

A sliding window is used, so when a new sample is obtained, the last one is rejected. In this way, once what it is analysed is a pattern, problems such as sampling misalignment and time delay of the communication channel are attenuated.

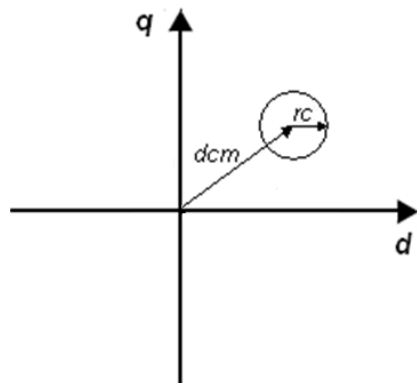

Fig. 3. Definition the circumference radius and the distance between the mass center and the origin.

3 Case Study

The proposed approach was tested through a case study of a transmission line with 500 km at 520 kV. This case study was made by simulation, using the software program Matlab/Simulink and the Power System Blockset.

Several tests have been made in order to evaluate the effectiveness of the proposed approach. In these tests, different fault types have been simulated. However, the first test result was made for the transmission line without a fault. Fig. 4 presents the pattern figures in the spaces “dq” and “do” for the differential currents. In the spaces “dq” and “do” it is obtained a single point. The obtained circumference radius is nearly zero and the mass centre is 1243 A. A second test was made for the transmission line with a three-phase short circuit fault. In Fig. 5 it is possible to verify the new patterns obtained for this test. In the space “dq” it is obtained again a single point. However, the distance between the obtained point and the origin increases. In this way, the circumference radius is still nearly zero but the mass centre increased for 4716 A. The homopolar component is nearly zero.

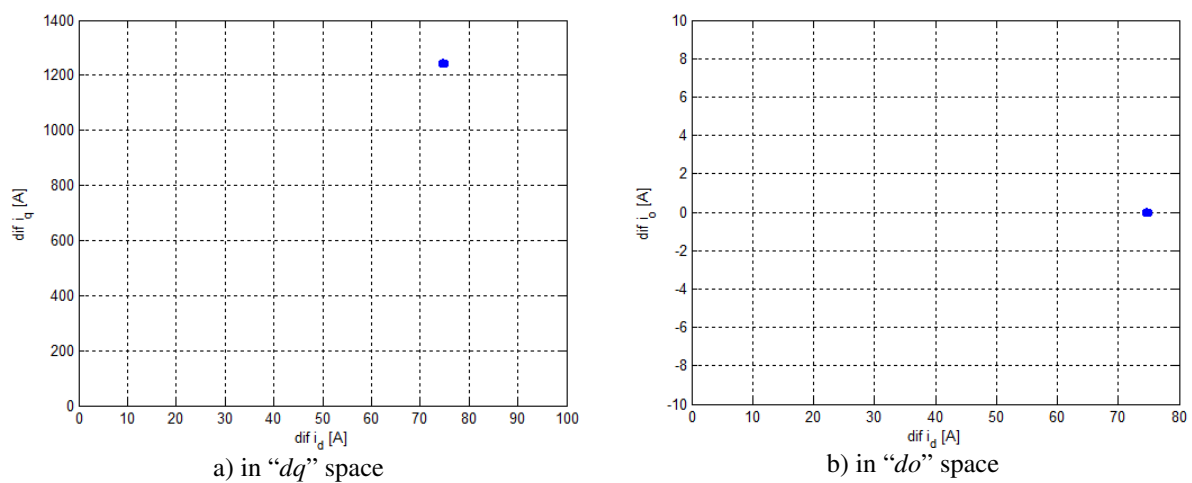

Fig. 4. Distribution of the differential line currents for steady state condition.

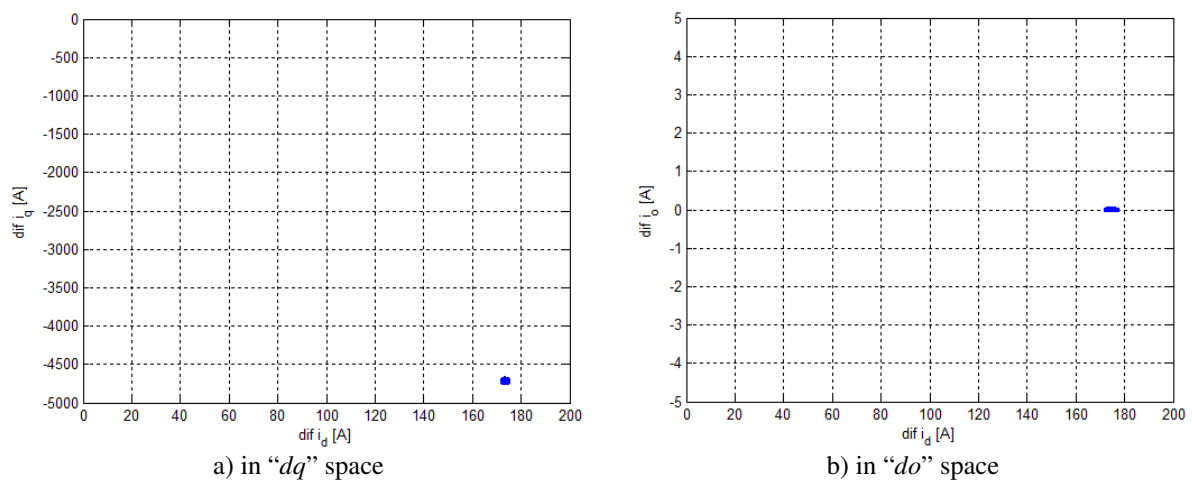

Fig. 5. Distribution of the differential line currents for a three-phase short circuit.

Fig. 6 shows the pattern figures in the spaces “dq” and “do” for the differential currents, for a simulation with a phase to phase short circuit. From this figure it is possible to verify that in the spaces “dq” a new pattern is obtained, more specifically, a circumference. This is due to the inverse components. In this test, the obtained circumference radius is 2478 A and the mass centre is 2512 A.

For the plane “do” it is obtained a nearly eight shape. However, from the space “do” it is possible to verify that the homopolar peak to peak is very small, namely 0,250 A.

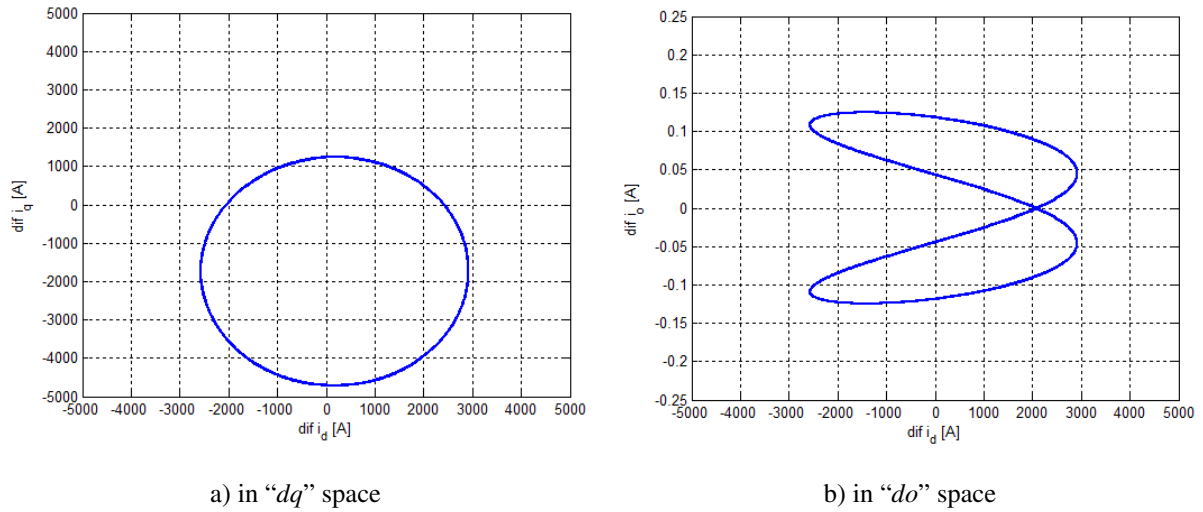

Fig. 6. Distribution of the differential line currents for a phase to phase short circuit.

The obtained patterns of the differential currents in the spaces “dq” and “do” for a phase to ground fault are presented in Fig. 7. This test was made for a fault resistor of 10 Ω. From these figures it is possible to verify that in the space “dq” it is obtained a circumference. For the plane “do” it is obtained a nearly eight shape. The obtained circumference radius is 988 A and the homopolar peak to peak is 2348 A. As expected the homopolar peak to peak presents a very high value. This and the obtained circumference in the space “dq” indicate a phase to ground short circuit.

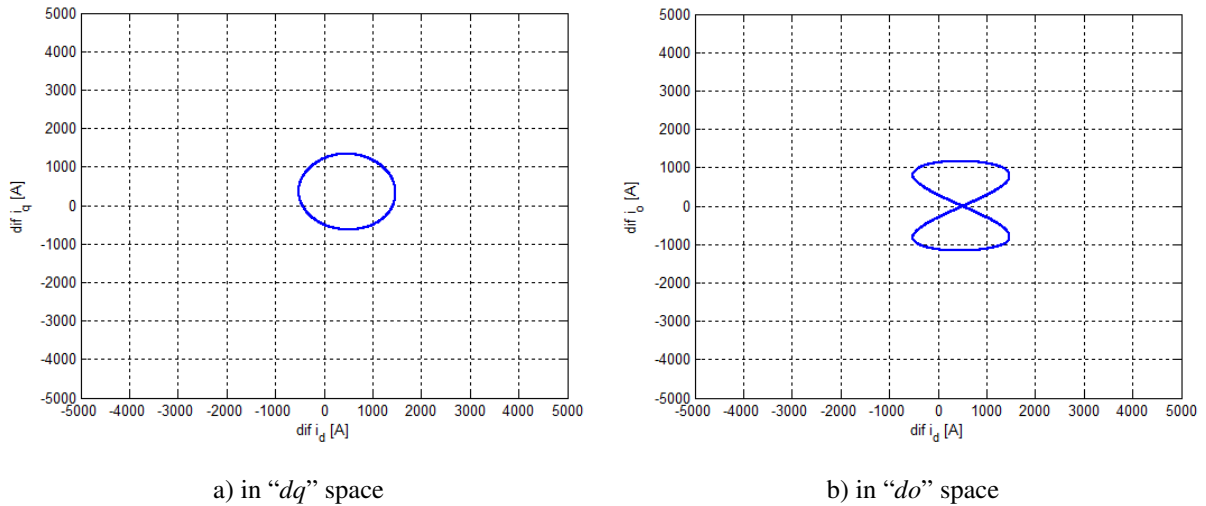

Fig. 7. Distribution of the differential line currents for a phase to ground short circuit.

Table I presents obtained results for circumference radius and homopolar peak to peak for several phase to ground short circuit tests. These tests were made for different fault resistor values. As expected with the increase of the fault resistor value there is a reduction of the circumference radius and homopolar peak to peak. However, it is possible to confirm the presence of a circle in the “dq” space in a phase to ground short circuit tests.

Table I: Circumference radius and homopolar peak to peak function of fault resistor

Fault resistor [Ω]	circumference radius [A]	homopolar peak to peak [A]
20	980	2278
50	960	2104
100	780	1846
1000	191	382

4 Conclusions

The analysis and application of a pattern recognition method for a transmission line current differential protection has been presented. In the proposed approach, the acquired current signals are transmitted to the other line terminal and, at the same time, transformed into “ dqo ” components by applying the Park Transform. The received currents acquired from the other line side are also time transformed into “ dqo ” components. Using the transformed currents of both sides of the transmission line it is obtained the differential currents. This allows obtaining different patterns according the fault type. These patterns are represented in the spaces “ dq ” and “ do ”. To identify the faulty operation it will be used the circumference radius and the distance between the mass centre and the origin. In order to confirm the proposed approach several simulation results for different situations have been presented.

References

- [1] Z.Y. Xu, S.J. Jiang, L. Ran, “Phase distance relaying algorithm for unbalanced inter-phase faults”, *IET Generation Transmission Distribution*, vol. 4, no. 12, pp. 1326–1333, 2010.
- [2] T. S. Sidhu, D. S. Ghotra, M. S. Sachdev, “An Adaptive Distance Relay and its Performance Comparison With a Fixed Data Window Distance Relay”, *IEEE Transactions on Power Delivery*, vol. 17, no. 3, pp. 691–697, 2002.
- [3] L. S. Martins, V. F. Pires, “A New Algorithm for Impedance Protection of Power Distribution Lines”, *First International ICSC Symposium on Artificial Intelligence in Energy Systems and Power (AIESP 2006)*, pp. 1–6, 2006.
- [4] N. El Halabi, M. García-Gracia, S. Martín Arroyo, A. Alonso, “Application of a distance relaying scheme to compensate fault location errors due to fault resistance”, *Electric Power Systems Research*, vol. 81, no. 8, pp. 1681–1687, 2011.
- [5] Y.C. Kang, E.S. Jin, S.H. Kang, P.A. Crossley, “Compensated-current differential relay for protection of transformers”, *IEE Proc.-Gener. Transm. Distribution*, vol. 151, no. 3, pp. 281–289, (2004).
- [6] B. Kasztenny, D. Finney, “New algorithm for generator differential protection”, *Eighth IEE International Conference on Developments in Power System Protection*, vol. 1, pp. 144–147, (2004).
- [7] M. Guerreiro, V. F. Pires, “A Transformer Differential Relay Based on a Multiple Park Transformation”, *International Conference on Power Engineering, Energy and Electrical Drives*, pp 400-404, (2007).
- [8] Tai NengLing, Ai Qian, Yin XiangGen, Chen DeShu, “New generator incomplete differential protection based on wavelet transform”, *Electric Power Systems Research*, vol. 69, no. 2-3, pp. 179–186, (2004).
- [9] J. Wheatley. “A microprocessor-based current differential protection”, in *Proc. 4th Int. Conf. Developments in Power System Protection, IEE Conf. Pub. 302*, pp. 116–120, (1989).
- [10] N. P. Albrecht, W. C. Fleck, K. J. Fodero, R. J. Ince. “Charge comparison protection of transmission lines-communications concepts”, *IEEE Transactions on Power Delivery*, vol. 7, no. 4, pp. 1853–1859, (1992).
- [11] Z. Y. Xu, Z. Q. Du, L. Ran, Y. K. Wu, Q. X. Yang, J. L. He. “A Current Differential Relay for a 1000-kV UHV Transmission Line”, *IEEE Transactions on Power Delivery*, vol. 22, no. 3, pp. 1392–1399, (2007).
- [12] H. Y. Li, E. P. Southern, P. A. Crossley, S. Potts, S. D. A. Pickering, B. R. J. Caunce, G. C. Weller. “A new type of differential feeder protection relay using the global positioning system for data synchronization”, *IEEE Transactions on Power Delivery*, vol. 12, no. 3, pp. 1090–1099, (1997).
- [13] V. F. Pires, M. Guerreiro, “A Current Differential Line Protection Using a Synchronous Reference Frame Approach”, *The 9th International Conference on Developments in Power System Protection*, pp 198-203, (2008).