



Comunidade sénior

O conceito de cohousing na criação
de uma comunidade sénior

Rafaela Resende Moreira

Mestrado em Design de Interiores

Orientador: Professor Paulo Alves Pereira

Co-orientadora: Professora Ana Sofia Carneiro e Cardoso

2022

ARTEMEST

LIGHTING : PENDANTS

G.Luce

GENERATOR PENDANT LAMP BY SIMONE FANCIULLACCI

€2.120

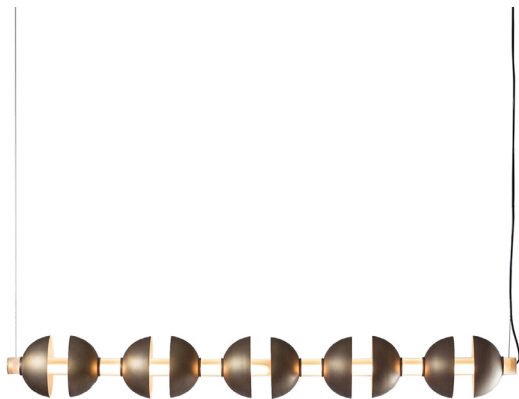

DESCRIPTION

Emblem of an innovative and refined design, this pendant lamp by Simone Fanciullacci will make an exquisite focal point above a contemporary dining table. Fashioned of satin plexiglass, it features ten half-spheres made of brass and finished in bronze. mounted on a brass bar enriched with bronze details. Also available in a floor or table variant, please check the Artemest catalog or ask the Concierge for details. Light is emitted from an LED strip.

DETAILS & DIMENSIONS

- Material: Bronze
- Dimensions (in): W 51.18 x D 5.91 x H 5.91
- Dimensions (cm): W 130 x D 15 x H 15
- Handmade In Italy

Planesit

Design by Lievore Altherr Valdés, 2018

Art. 6500

Chair with a 5 way nylon fibre reinforced swivel base (black or white) mounted on self-braking castors (in the same colour as the base, with soft or hard tread). Low backrest with exposed backshell in the same colour as the base with front face upholstery in nylon mesh (black or white). Seat upholstery available in fabric, leather, faux leather, or customer's material. 3D nylon adjustable armrests (black or white) with TPU pads in two sizes are available upon request and with a surcharge. Mechanisms: - Gas-lift mechanism for height adjustment. - Built-in self-tensioning weight response mechanism and backrest with 5-position recline. - Up&down of the backrest with 5-position recline, breathing up to 64mm and built-in lumbar support. - Sliding seat with 5-position adjustment, breathing up to 50mm.



Dimensions *

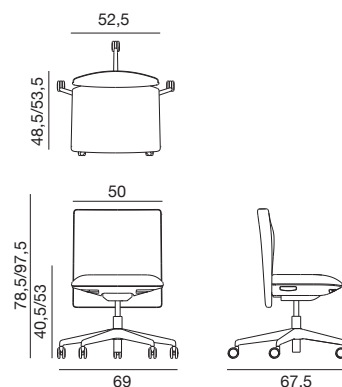

* File CAD 2D - 3D available for download at www.arper.com

Frame Base

Shell

arper

www.arper.com info@arper.com

Planesit

Design by Lievore Altherr Valdés, 2018

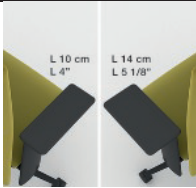

Amrest L 10 cm / L 14 cm

SHIPMENT DETAILS

Art.6500

1 pz = 1  - kg 20,7/ m³ 0,26

TECHNICAL SPECIFICATIONS

Art.6500

H 140 cm. COM Meterage ml 0,682

arper

www.arper.com
info@arper.com

www.arper.com

Molteni & C

ELAIN — VINCENT VAN DUYSSEN 2018

1—
2



Elain, is a cosy, curvacious, little armchair designed to fit easily into any setting. Consisting of just two parts, a seat and a backrest, which come together to form a perfectly rounded object that invites you simply to sit down. Ideal for use alongside sofas also designed by Vincent Van Duysen, or even on her own as a comfy armchair or with a twin to create discreet little conversation corners. Elain is not just a stay at home chair but one that loves to make an appearance in public hospitality spaces such as hotel or office lobbies. Whether upholstered in quality textiles or in soft leather, Elain is always herself: a pretty, sophisticated little chair, featuring snug, welcoming lines, thanks to the padded seat and back.



This symbol shows that the product has removable upholstery. Only qualified personnel can remove the upholstery of some of our products. If this information is pertinent, it will be included in the warnings section.



This symbol shows that the product is available on request in a fire resistant version that complies with the standards BS 5852 and TB 117-2013.

The buyer is responsible for checking to make sure that the product is suitable and compliant with the requirements for the designated use and the current applicable laws and standards for the destination and use of the product.

DATASHEET
REGISTERED
DESIGN

IX.2021

moltenigroup.com

Dimensions in centimeters and inches. The right to discontinue and make changes is reserved. This information is based on the latest product information available at the time of printing

FINISHES

FEET FINISHES
pewter colour

SWIVEL BASE FINISHES
black

TECHNICAL INFORMATION

INSIDE STRUCTURE

Frame made of solid Fir (Picea abies) and wood particle panels with elastic straps.

STRUCTURE PADDING

Polimex infills with high performance variable density polyurethane foam. Cover in bonded velveteen.

FEET

Painted aluminium with plastic tips.

SWIVEL BASE

Painted steel with plastic tips.

REMOVABLE OUTER COVER

(See enclosed label, specific for the cover in question).



AVAILABLE IN FIRE-RESISTANT
VERSION TB117 AND BS5852

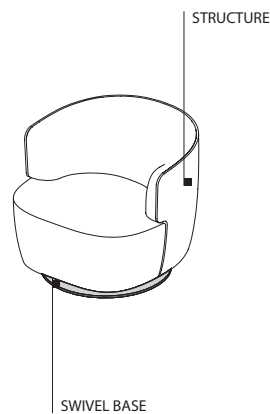
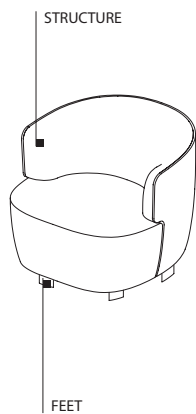

DIMENSIONS

armchair

HPL1

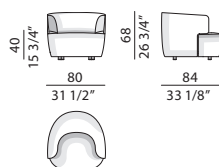

swivel armchair

HPL2

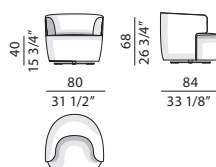

DATASHEET

REGISTERED
DESIGN

IX.2021

code	gross weight kg.	volume mc.	packages	code	gross weight kg.	volume mc.	packages
HPL1	26	0,614	1	HPL2	38	0,628	1

Molteni & C

PANNA COTTA — RON GILAD 2012

1—
2



Panna Cotta low table oval or round. At once delicate and heavy, the paradox lies in the use of materials such as marble and iron to achieve a fragile stability. A small table, it has a slight wave on top reminiscent of the typical Italian soft dessert, from which it takes its name.

DATASHEET

REGISTERED
DESIGN

IX.2021

moltenigroup.com

Dimensions in centimeters and inches. The right to discontinue and make changes is reserved. This information is based on the latest product information available at the time of printing.

FINISHES

matt white lacquer with white Carrara marble
matt black lacquer with black marquina marble
matt red lacquer with red Laguna marble (only for small round tables)

Molteni & C

TECHNICAL INFORMATION

STRUCTURE

Welded drawn steel painted in the colours of the range. Nylon foot.

TOP

Steel sheet painted in the colours of the range.

COUNTERWEIGHT

Marble in the finishes of the range.

2—
2

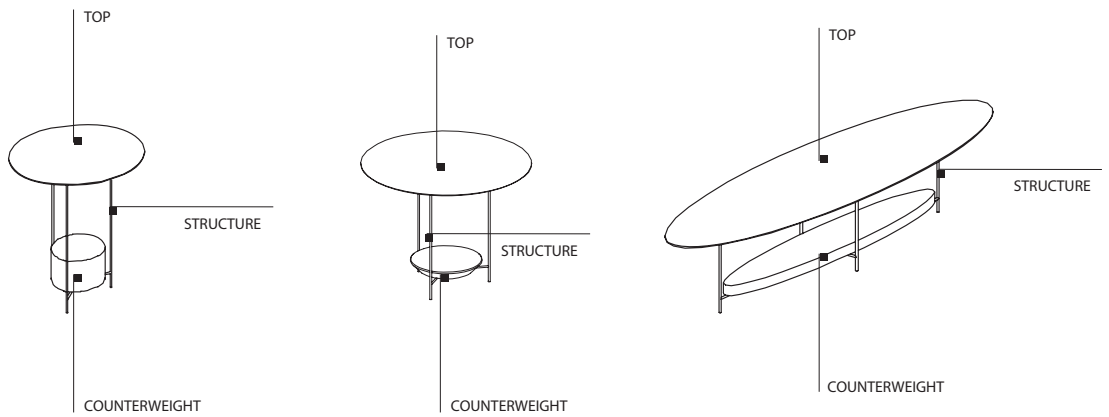

DIMENSIONS

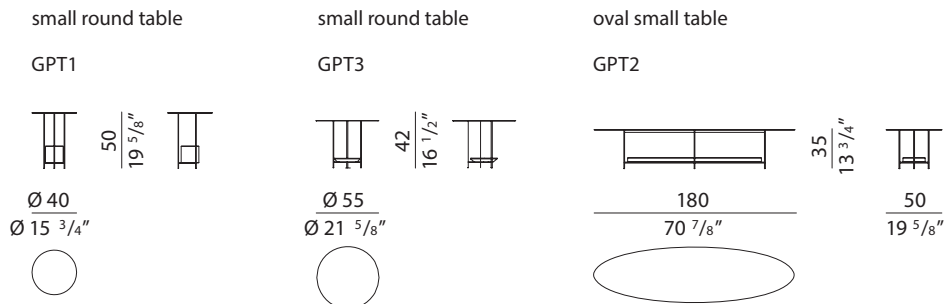

DATASHEET

REGISTERED
DESIGN

IX.2021

Molteni & C

CLEO — VINCENT VAN DUYSSEN 2022

1—
6



Cleo is a modular system consisting of various rectilinear, angular and self-standing elements that allow for a large number of compositions suitable for all kinds of living. The heart of the project is the frame, which is used for each individual component. A harmonious curvilinear shell, recalling a cosy place, which embraces seat and back without a break. The shell, upholstered in textiles or in leather, like the seat cushions, offers great comfort. The possible combinations between the various upholstery materials for covering the frame and the seat cushions, can either make a contrast or emphasize the harmony of the two components. The rectangular back cushions can be placed at will to satisfy any requirements, guaranteeing comfort and allowing for different relaxation positions: from sitting comfortably to read a good book or spending time with loved ones, to lying down for a brief rest. Cleo is supported by feet made of a thin layer of varnished steel, designed to make the sofa look like an object floating in the living area, thus become heart and protagonist, thanks to its easy collocation even in the centre of the room. In addition, Cleo has rectilinear single frame solutions, suitable for creating a sofa with complete and enveloping shapes.



This symbol shows that the product has removable upholstery. Only qualified personnel can remove the upholstery of some of our products. If this information is pertinent, it will be included in the warnings section.



This symbol shows that the product is available on request in a fire resistant version that complies with the standards BS 5852 and TB 117-2013.

The buyer is responsible for checking to make sure that the product is suitable and compliant with the requirements for the designated use and the current applicable laws and standards for the destination and use of the product.

DATASHEET

REGISTERED
DESIGN

IV.2022

TECHNICAL INFORMATION

EXTERNAL STRUCTURE

Frame made of plywood panels and wood cellulose fibreboard panels with thermosetting synthetic resin.
Cover in velveteen bonded with polyurethane .

INTERNAL CUSHIONING:

Padded back

Frame made of plywood panels and Polimex (polyester/polyurethane composite material), upholstered with high-bearing, variable-density polyurethane foam.

Cotton-polyester bonded velveteen lining.

Seat cushion

High-bearing, variable-density polyurethane foam and polyester fibre.
100% cotton cover.

BACK CUSHIONS

Polyester fibre. 100% cotton cover.

FEET

Pewter colour finish metal.

REMOVABLE OUTER COVER

(See attached card, specifically for the cover).



AVAILABLE IN FIRE-RESISTANT
VERSION T8117 AND B55852

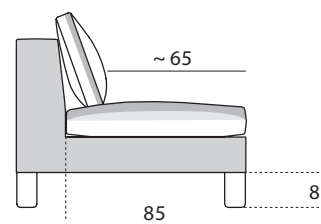
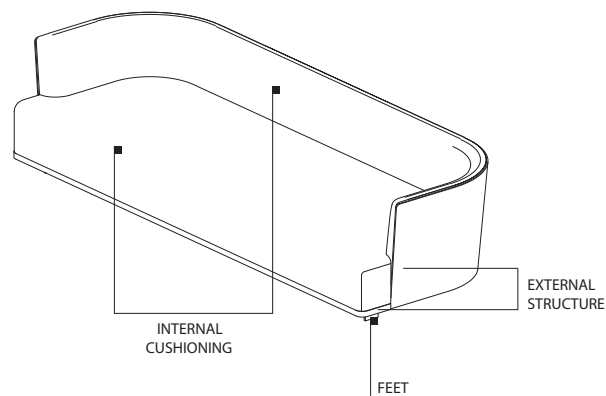

Seat depth for structure only, 85 cm
Seat depth with backrest cushion, ~ 65 cm
Feet high 8 cm (from ground to under seat)

RECOMMENDED BACK CUSHIONS CONFIGURATIONS



back cushion
W 45 H 45
CCS45



back cushion
W 55 H 50
CCS55



back cushion
W 75 H 50
CCS75

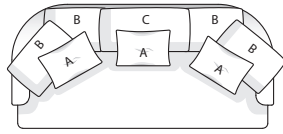

sofa W 210

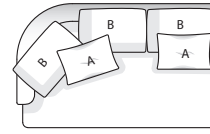

end element W 160 sx

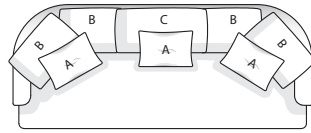

sofa W 240

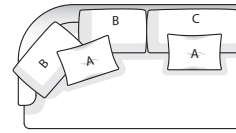

end element W 180 sx

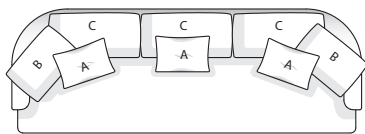

sofa W 280

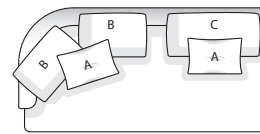

end element W 200 sx

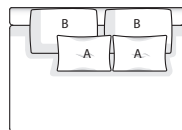

central element W 140

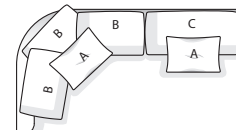

corner element W 180 dx

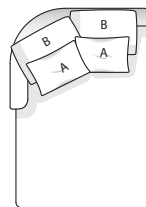

chaise longue W 160 sx

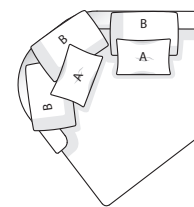

curved chaise longue W 162 sx

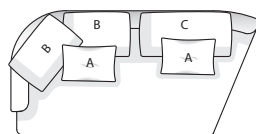

curved end element W 200 sx

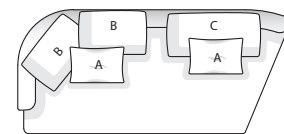

curved end element W 220 sx

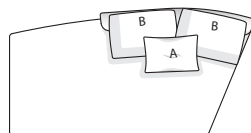

curved island element W 196,5 sx

NOTES

For optimal ergonomics and comfort, we recommend designing each module with one or more back cushions, using the measurements set forth in the price list. In addition to optimal ergonomics, these elements complete the product and ensure an elegant aesthetic appearance.

DATASHEET

REGISTERED
DESIGN

IV.2022

Molteni & C

3—
6

DIMENSIONS

Recommended configuration for back cushions:
nr. 4 - CCS55
nr. 1 - CCS75
nr. 3 - CCS45

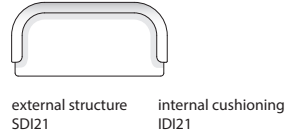
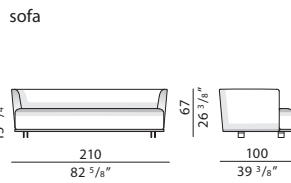

back cushion
CCS55



back cushion
CCS75

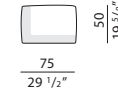

back cushion
CCS45



ornamental cushion
PCU90/75

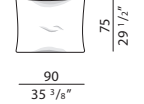

Recommended configuration for back cushions:
nr. 4 - CCS55
nr. 1 - CCS75
nr. 3 - CCS45

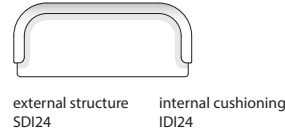
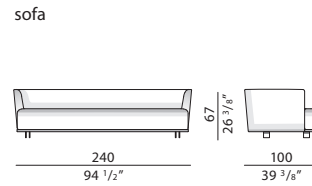

back cushion
CCS55



back cushion
CCS75

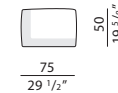

back cushion
CCS45



ornamental cushion
PCU90/75

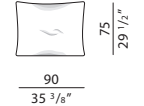

Recommended configuration for back cushions:
nr. 2 - CCS55
nr. 3 - CCS75
nr. 3 - CCS45

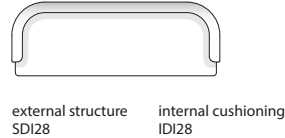
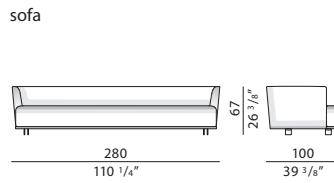

back cushion
CCS55



back cushion
CCS75

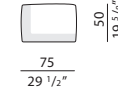

back cushion
CCS45



ornamental cushion
PCU90/75

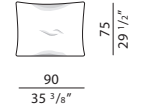

Recommended configuration for back cushions:
nr. 3 - CCS55
nr. 2 - CCS45

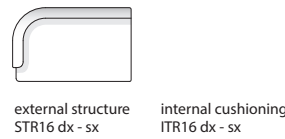
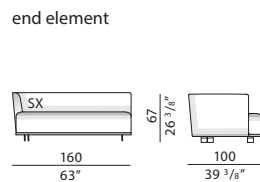

back cushion
CCS55



back cushion
CCS75

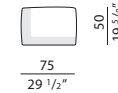

back cushion
CCS45



ornamental cushion
PCU90/75

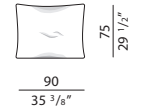

Recommended configuration for back cushions:
nr. 2 - CCS55
nr. 1 - CCS75
nr. 2 - CCS45

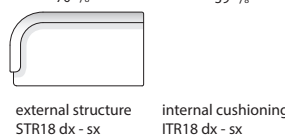
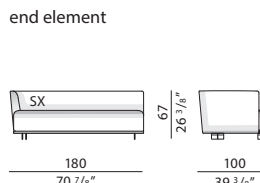

back cushion
CCS55



back cushion
CCS75

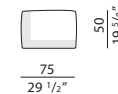

back cushion
CCS45



ornamental cushion
PCU90/75

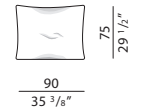

DIMENSIONS

Recommended configuration for back cushions:
nr. 2 - CCS55
nr. 1 - CCS75
nr. 2 - CCS45

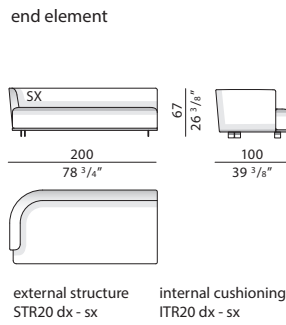

back cushion
CCS55

55
21 5/8"

back cushion
CCS75

75
29 1/2"

back cushion
CCS45

45
17 3/4"

ornamental cushion
PCU90/75

90
35 3/8"

75
29 1/2"

Recommended configuration for back cushions:
nr. 2 - CCS55
nr. 2 - CCS45

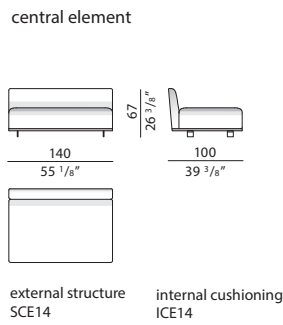

back cushion
CCS55

55
21 5/8"

back cushion
CCS75

75
29 1/2"

back cushion
CCS45

45
17 3/4"

ornamental cushion
PCU90/75

90
35 3/8"

75
29 1/2"

Recommended configuration for back cushions:
nr. 3 - CCS55
nr. 1 - CCS75
nr. 2 - CCS45

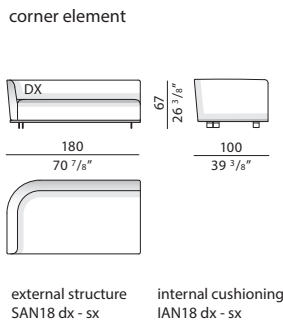

back cushion
CCS55

55
21 5/8"

back cushion
CCS75

75
29 1/2"

back cushion
CCS45

45
17 3/4"

ornamental cushion
PCU90/75

90
35 3/8"

75
29 1/2"

Recommended configuration for back cushions:
nr. 2 - CCS55
nr. 2 - CCS45

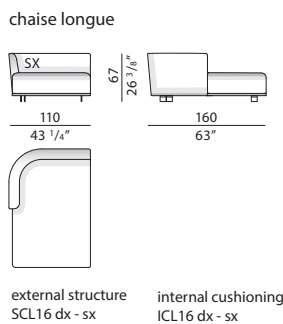

back cushion
CCS55

55
21 5/8"

back cushion
CCS75

75
29 1/2"

back cushion
CCS45

45
17 3/4"

ornamental cushion
PCU90/75

90
35 3/8"

75
29 1/2"

Recommended configuration for back cushions:
nr. 3 - CCS55
nr. 2 - CCS45

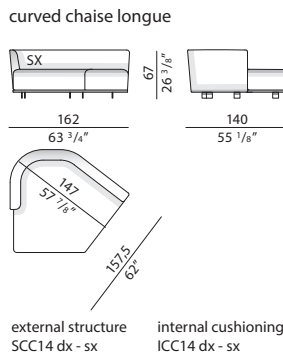

back cushion
CCS55

55
21 5/8"

back cushion
CCS75

75
29 1/2"

back cushion
CCS45

45
17 3/4"

ornamental cushion
PCU90/75

90
35 3/8"

75
29 1/2"

DIMENSIONS

Recommended configuration for back cushions:
nr. 2 - CCS55
nr. 1 - CCS75
nr. 2 - CCS45

curved end element

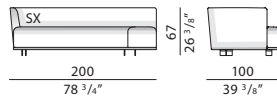

external structure
STC20 dx - sx

internal cushioning
ITC20 dx - sx

back cushion

CCS55

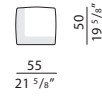

back cushion

CCS55

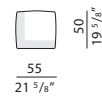

back cushion

CCS75

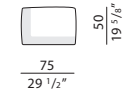

back cushion

CCS75

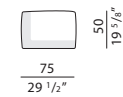

back cushion

CCS45

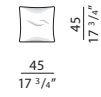

back cushion

CCS45

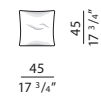

ornamental cushion

PCU90/75

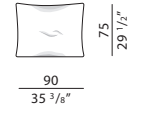

ornamental cushion

PCU90/75

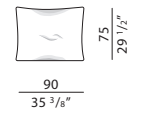

Recommended configuration for back cushions:
nr. 2 - CCS55
nr. 1 - CCS75
nr. 2 - CCS45

curved end element

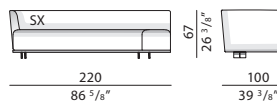

external structure
STC22 dx - sx

internal cushioning
ITC22 dx - sx

back cushion

CCS55

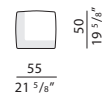

back cushion

CCS75

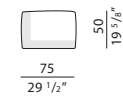

back cushion

CCS45

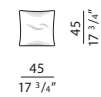

ornamental cushion

PCU90/75

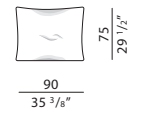

Recommended configuration for back cushions:
nr. 2 - CCS55
nr. 1 - CCS45

curved island element

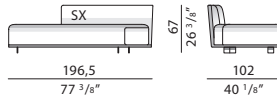

external structure
SIC20 dx - sx

internal cushioning
IIC20 dx - sx

back cushion

CCS55

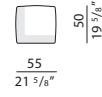

back cushion

CCS75

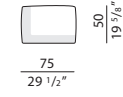

back cushion

CCS45

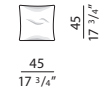

ornamental cushion

PCU90/75

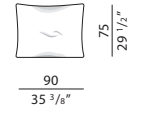

pouf

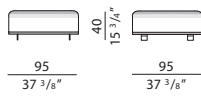

base
SPF95

seat cushion
IPF95

FLOS

F9520034 Pink

Wireline

Designed by Formafantasma, 2019

45W - 2793lm - 2700K - CRI> 90

Suspension lamp with diffused light. Tubular in transparent extruded glass and internal diffuser in opal PC. Ferrules made with CNC technology in satin stainless steel. Extruded cable in pink and forest green rubber. Injection molded PC rosette in the same finishes as the cable. The electronics integrated in the ceiling rose allows the use of different dimerization systems: push, 1-10, potentiometer, DALI. In the absence of these systems, the luminous flux can be set during installation, with the push system included in the canopy. Useful length of the cable 3m.

Are you a professional and your project needs consulting and support?

[BOOK AN APPOINTMENT](#)

Main specifications

EAN	8059607034514
Mounting	Suspension
Environment	Indoor dry location
Light source type	LED
LED type	LED Module
Lamp holder	LED Module
Number of heads	1
Power (W)	45
System power (W)	45
System flux (lm)	2793

Physical

Colour	Pink
Length (mm)	1300
Cord length (mm)	2000/4050
Net weight (kg)	7.8
Package volume (m3)	0.05
IP	20
IP external	20

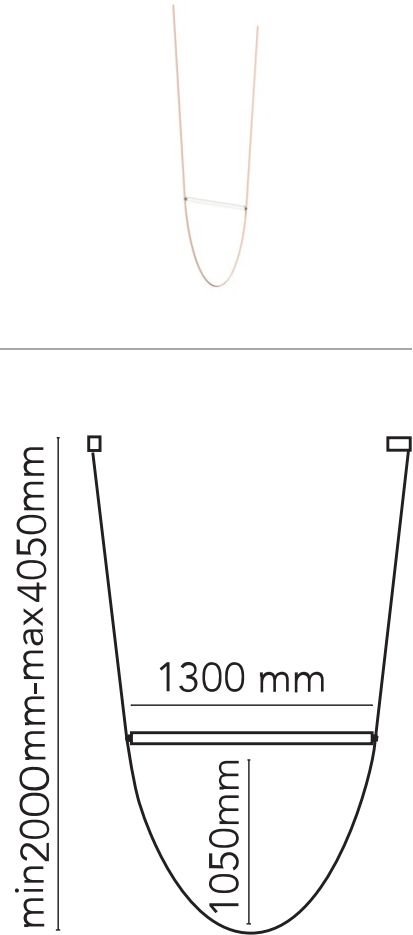

Download

[Mounting instructions](#)  PDF

Photometric Files

[LDT / IES](#)  LDT

Technical Drawings

[3D](#)  ZIP



Schematic light drawing

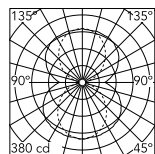

Luminous flux luminaire
2793 lm

The above drawing is for illustrative purposes only and refers to product code: F95200WWIRELINE_45W-LED

Photometric

Lighting type	Total
Light distribution	Symmetric
CCT (K)	2700
CRI>	90

Electrical

Insulation class	I
Frequency (Hz)	50/60
Main voltage (Vac)	120-277
Driver	Integrated
Dimming type	Dimmable 0-10V, Dimmable Push, Dimmable 1-10V, Dimmable DALI 1
Cord length (mm)	2000/4050
Batteries inside	No

Ecodesign and Energy Labelling

This product contains a light source of energy efficiency class F



Replaceable (LED only) light source by a professional



Replaceable control gear by a professional

Caboche Plus, sospensione

by Patricia Urquiola , Eliana Gerotto

FOSCARINI



DESCRIPTION

Caboche was created in 2005 as a result of the desire to create a precious and charming lamp like a pearl brace-let, accommodated with a focus on light weight and transparency. Rich, bright and sophisticated, it was a success from the onset, becoming one of Foscarini's biggest bestsellers, and went on to become a genuine icon of designer lighting. It is now presented in the Plus version, with a new LED which guarantees a more in-tense light yet without creating glare. Total transparency wins in Caboche Plus, as your eyes roam through the entire lamp thanks to the new zigzagging arches which do not shield the light. What's more, the new attachment system, which is even simpler and more user-friendly, guarantees greater stability for the sphere and makes it simply to use.

MATERIALS

PMMA, steel and liquid coated aluminium

COLORS

Grey, Transparent

Caboche Plus, sospensione

technical details

FOSCARINI

Suspension lamp with diffused light. Structure comprising transparent PC arches, onto which a series of PMMA spheres are applied, using the new twist lock system. The lamp body consists of two powder coated steel sheets, which incorporate the double-sided LED board, designed specifically by Foscarini, thereby obtaining a superior level of colour rendering (CRI) and retaining the same colour temperature as a halogen light source (degrees Kelvin). The LED board is installed on an aluminium disc that acts as a dissipator, which is protected at the top by a small opaline PMMA disc and at the bottom by a satin-finish PMMA diffuser. Three-point suspension system with steel cables. White ceiling canopy. Electric decentralisation kit available.

Caboche Plus grande LED

SCHEMATIC & LIGHT EMISSION

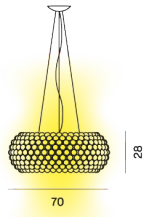

MATERIAL

PMMA, steel and liquid coated aluminium

COLORS



ACCESSORIES

Caboche Plus

LIGHT SOURCE

LED included
28W
2700 K 3850 lm CRI>90
dimmable

CERTIFICATIONS



ENERGY EFFICIENCY

A+

Caboche Plus, sospensione

Designer

FOSCARINI

PATRICIA URQUIOLA

An internationally renowned architect and designer, Patricia Urquiola has received multiple major acknowledgements such as the “Designer of the Decade” title from the Home and Häuser magazines, and “Designer of the Year” from Wallpaper, Ad Spain, Elle Decor International and Architektur und Wohnen Magazine.

Some of her projects are exhibited in several museums and collections. Together with Eliana Gerotto, industrial designer, curator of outfits and interior decorator, she has designed Caboche, a precious, luminous emotion that stems from a combination of technology and creativity.



Caboche Plus, sospensione

Designer

FOSCARINI

ELIANA GEROTTO

A Venetian, she obtained her diploma in Communication Techniques in Milan. She has worked as a graphic designer for the Parisian magazine, Elle, and for the Venice Biennale, while she co-operates with some major Italian brands as image and product consultant.

Her creative entrepreneurship drives her towards ever-differing professional experiences, from interior designs to furnishings and even jewellery. Together with Patricia Urquiola, she has designed Caboche, a precious, luminous emotion that stems from a combination of technology and creativity.



Arkos



collection booklet

Models & Dimensions

round

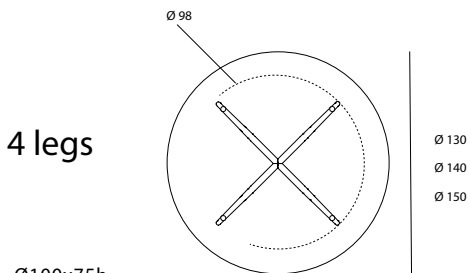
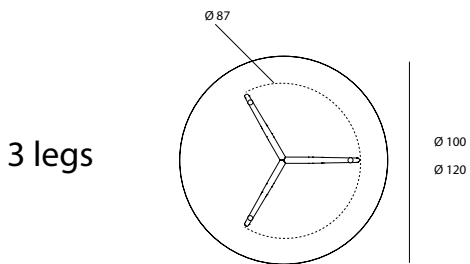

Ø100x75h
Ø120x75h
Ø130x75h
Ø140x75h
Ø150x75h

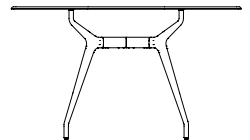
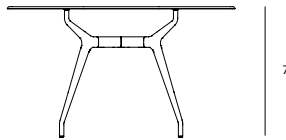
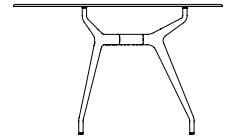
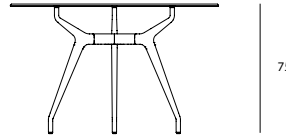

rectangular

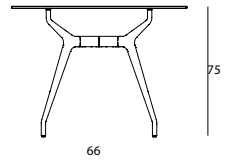
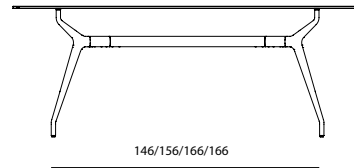
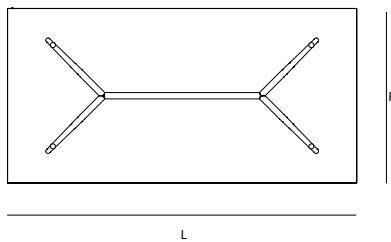

180x90x75h
200x90x75h
240x120x75h
250x100x75h

shaped square

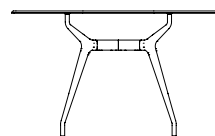
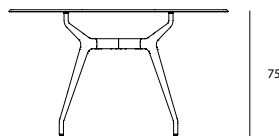
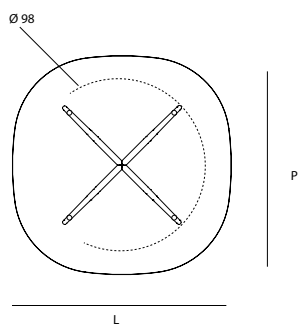

- 100x100x75h
- 120x120x75h
- 130x130x75h
- 140x140x75h
- 150x150x75h

5

shaped rectangular

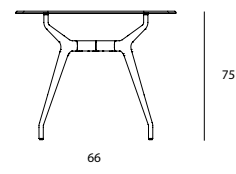
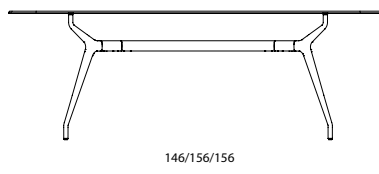
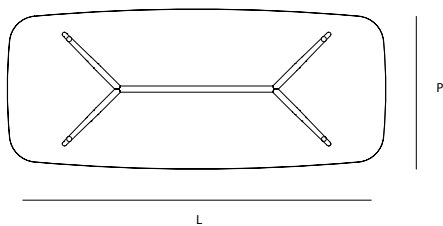

- 180x93x75h
- 200x93x75h
- 220x93x75h

75

/ The Arkos series arises from the desire to relive the taste of the Italian domestic interiors of the 50s. The aerodynamic lines and curvilinear tensions of the shape are inspired by the designs of Ico Parisi and respect the emblem of the Italian furniture style of these years. Reinterpreted with a contemporary taste and made with cutting-edge techniques such as the aluminium die-casting for the base, Arkos stands out for the strong structural bareness of the X or Y legs with its thin and slender shape.

/ La serie Arkos nasce dalla volontà di rivivere il sapore degli interni domestici italiani degli anni 50. Le linee aerodinamiche e tensioni curvilinee della forma si ispirano ai progetti di Ico Parisi e rispettano l'emblema dello stile del mobile italiano di questi anni. Reinterpretato con un gusto contemporaneo e realizzato con tecniche d'avanguardia come la pressofusione di alluminio per la base, Arkos si distingue per la spiccata nudità strutturale delle gambe a X o Y con la sua esile e longilinea forma.

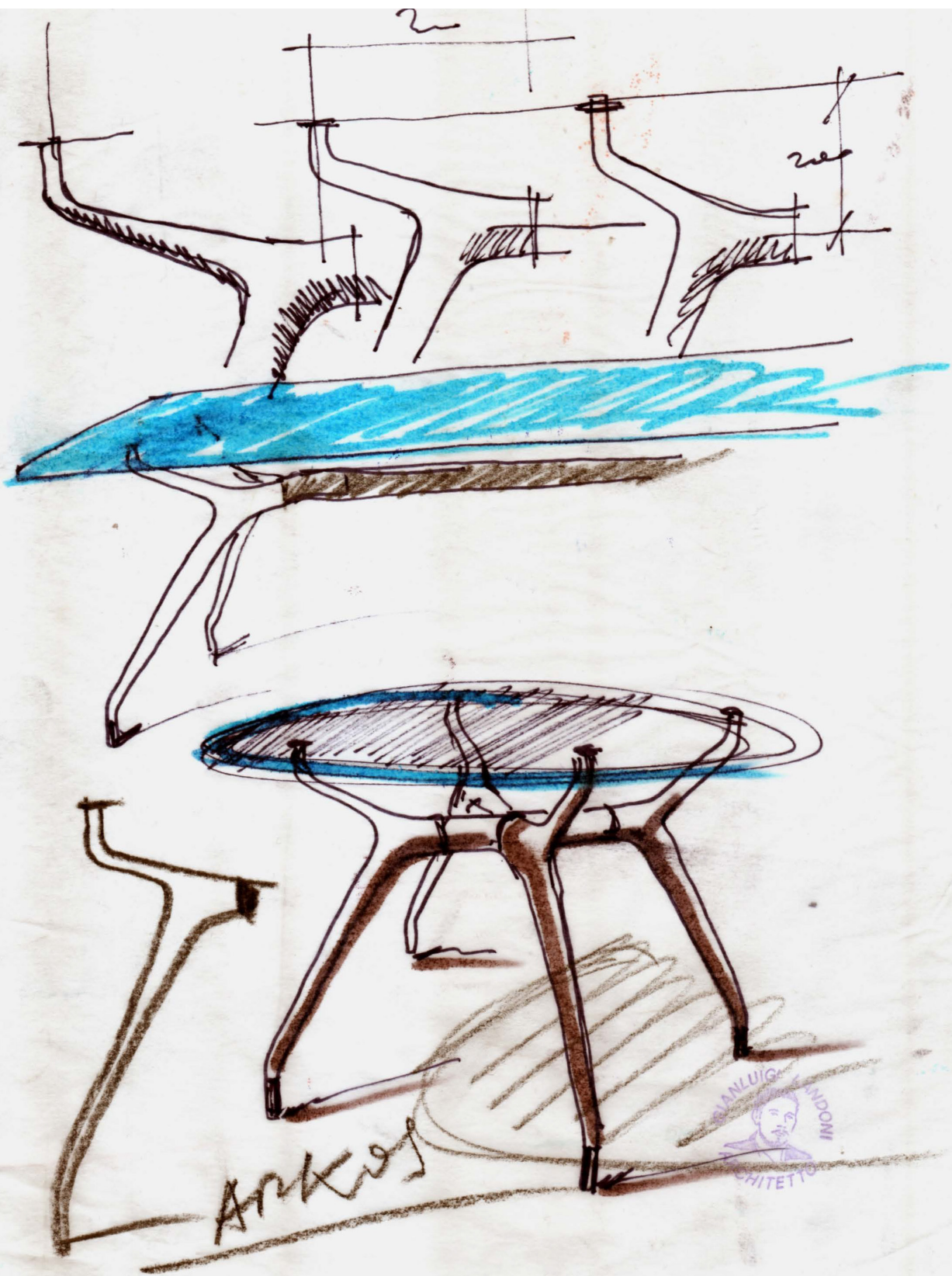

collection finishes



top

Glass
Vetro



TETE
Extralight glass
Vetro extrachiaro



TFTF
Smoked glass
Vetro fumé



TBTB
Bronzed glass
Vetro bronzo

CAT. B



TEB1
Extralight glass lacquered
milky white
Vetro extrachiaro laccato
bianco latte



TEC1
Extralight glass
lacquered mocha
Vetro extrachiaro
laccato caffè



TEC2
Extralight glass
lacquered clay
Vetro extrachiaro
laccato creta



TEC3
Extralight glass
lacquered cement
Vetro extrachiaro
laccato col. cemento



TER4
Extralight glass
lacquered rust
Vetro extrachiaro
laccato col. ruggine

10



TEV2
Extralight glass
lacquered moss green
Vetro extrachiaro
laccato col. muschio



TEN1
Extralight glass
lacquered black
Vetro extrachiaro
laccato nero

CAT. D



TEM6
Vetro extrachiaro
laccato col. tabacco
Extralight glass
lacquered tobacco



TES1
Vetro extrachiaro
laccato champagne
Extralight glass lacquered
champagne

Frosted glass
Vetro acidato

CAT. E



AEAE
Vetro acidato
Frosted glass



AEB1
Extralight glass
lacquered mocha
Vetro extrachiaro
laccato caffè



AEC2
Frosted clay glass
Vetro acidato creta



AEC3
Frosted
cement glass
Vetro acidato
col. cemento



AES1
Frosted champagne
glass
Vetro acidato
champagne

Net glass



NEB1
White Net glass
Net glass bianco



NEC1
Mocha Net glass
Net glass caffè

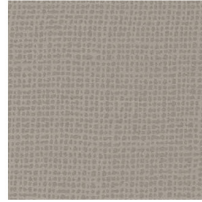

NEC2
Clay Net glass
Net glass creta

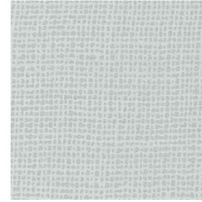

NEC3
Cement Net glass
Net glass col. cemento

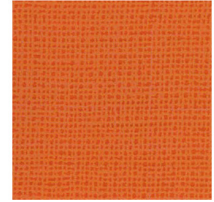

NER4
Rust Net glass
Net glass col. ruggine

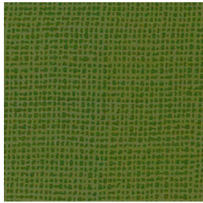

NEV2
Moss green Net glass
Net glass col. muschio

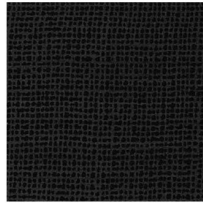

NEN1
Black Net glass
Net glass nero

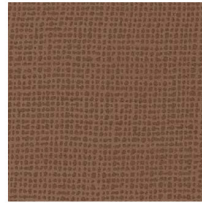

NEM6
Tobacco
Net glass
Net glass col.
tabacco



NES1
Champagne
Net glass
Net glass
champagne

Liquid glass



LFLF
Smoked Liquid glass



LBLB
Bronzed Liquid glass

Materia



MESP
Pearly
materia glass
Vetro materia
perlato



MBSP
Bronzed
materia glass
Vetro materia
bronzo

Wood
Legni

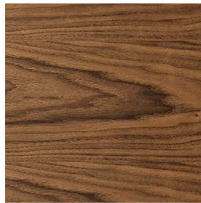

NC
Canaletto walnut
Noce Canaletto



RN
Natural oak wood
Rovere naturale



RG
Grey lacquered oak
Rovere tinto grigio



WG
Wengé-stained oak
Rovere tinto wengé

Ceramic
Ceramica
Categoria CE1

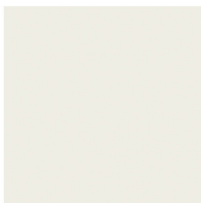

CT
Ceramic titanio
Ceramica titanio

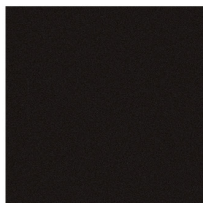

CJ
Ivory black ceramic
Ceramica Ivory Black

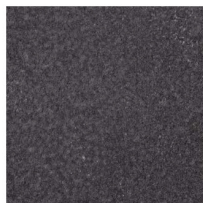

CD
Dark ceramic
Ceramica dark



CG
Grey ceramic
Ceramica grey



CZ
Ceppo di Grè ceramic
Ceramica Ceppo di Grè



CC
Pre-polished Calacatta
ceramic
Ceramica Calacatta
Prelucidata



CX
Pre-polished Stone
Grey ceramic
Ceramica Stone Grey
Prelucidata



KC
Corten ceramic
Ceramica Corten

Ceramic
Ceramica
Categoria CE1



CA
Arabescato light ceramic
Ceramica Arabescato light

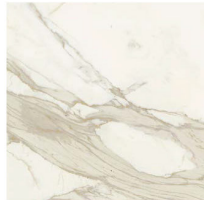

CL
Polished Calacatta ceramic
Ceramica Calacatta lucida



CY
Stone grey ceramic
Ceramica Stone grey



CU
Gaudi Stone ceramic
Ceramica Gaudi Stone lucida

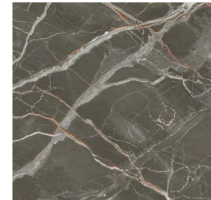

CV
Ombra di Caravaggio ceramic
Ceramica Ombra di Caravaggio

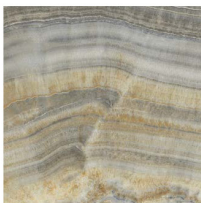

CH
Grey onyx ceramic
Ceramica Onice grigio



CI
Gold Onyx ceramic
Ceramica Onice oro

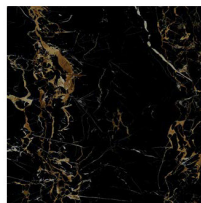

CO
Portoro ceramic
Ceramica Portoro



CQ
Polished Marquina ceramic
Ceramica Marquina lucida



CF
Eramosa ceramic
Ceramica Eramosa



CW
Antique ceramic
Ceramica Antique

base

Aluminium
Alluminio



GN
Embossed black
Nero gofrato



GB
Embossed white
Caffè gofrato



GC
Embossed Mocha
Caffè gofrato



GT
Embossed clay
Caffè gofrato



BR
Burnished metal
Metallo brunito

Materiali e manutenzione

ITA

Vetro

Le laccature utilizzate non presentano problemi di durata: basta evitare graffi e urti contro oggetti particolarmente duri e spigolosi. Il vetro è colorato solo sulla faccia posteriore sia nei vetri laccati coprenti mono e bicolore che nei vetri acidati laccati. La tonalità dei campioni proposti è indicativa e non va pertanto intesa in senso restrittivo; può infatti differire leggermente in conformità ai margini di tolleranza riconosciuti per i materiali impiegati. I materiali impiegati possono essere puliti tranquillamente solo con acqua oppure con un detergente neutro. Evitare l'uso di abrasivi, acidi o reagenti chimici. Il vetro è interpretato attraverso la sua trasparenza, pertanto la conformità al campione può differire a seconda della superficie e degli spessori impiegati. Un esempio lampante è dato dal vetro extrachiaro che nei campioncini si presenta completamente neutro ma che nei piani di dimensioni maggiori e con spessori più consistenti assume sfumature azzurro/verdi. Per tale ragione vi preghiamo anche di segnalare con particolare attenzione articoli che debbano essere affiancati o facenti parte di una stessa commissione.

La finitura bicolore consiste nella doppia laccatura nella parte interna della lastra di vetro. La prima laccatura, visibile attraverso la trasparenza del vetro, è disponibile nelle categorie B-D. La seconda laccatura, visibile internamente, equivale al colore pastello opaco utilizzato per ottenere le finiture di cat. B. Vi facciamo presente che in questo caso l'effetto finale differisce da quello creato dalla medesima laccatura attraverso il vetro, in particolare nei colori tenui.

Specchi

Gli specchi oro e rosa potrebbero presentare delle piccole imperfezioni dovute alle caratteristiche tecniche del materiale. Non possono essere utilizzati in luoghi umidi. Pulire solo con panni asciutti.

Ceramica

I campioni riportati sono una parte delle lastre che vengono lavorate. La lastra completa si può vedere nella corrispondente cartella. Pulire utilizzando acqua e una piccola quantità di detergente neutro. Evitare l'utilizzo di detergenti contenenti cere e prodotti ceranti per evitare la formazione di strati untuosi.

Legno

I colori dei legni sono campioni indicativi. Pulire utilizzando un panno morbido inumidito.

Metalli

I colori dei metalli sono campioni indicativi. Pulire utilizzando un panno morbido inumidito.

Tessuti/Pelli/Ecopelli/Velluti

I colori dei tessuti sono campioni indicativi. Per la cura e la manutenzione fare riferimento alle indicazioni riportate nelle rispettive cartelle e alle schede tecniche fornite dai produttori.

Se permangono dubbi contattare l'azienda.

Colours and maintenance

ENG

Glass

The lacquering used for our furniture is extremely durable as long as you avoid scratching it or bumping particularly hard/sharp objects against it. The glass is lacquered only on the back side both for mono or two-tones lacquered and frosted lacquered glasses. The shade of the samples is only indicative and has not to be taken as restrictive. It can in fact slightly differ in conformity to the tolerances recognized for the materials used. All the materials we use can be easily cleaned with water only or with a mild detergent. Do not use abrasive materials, acids or harsh chemicals. The glass is interpreted through its transparency, therefore the conformity to the sample might differ according to the surface and the thickness used. For example, the extralight glass is completely neutral when seen in the small samples, but it takes a light blue/greenish shade when used on bigger or thicker tops. For this reason, we beg you to indicate carefully those articles which have to be placed side by side or which are part of the same commission.

The two-tones finish consists of a double lacquering on the internal part of the glass sheet. The first lacquering, which is visible through the transparency of the glass, is available in the finishes of cat. B-D. The second lacquering, which is visible internally, is the same of the mat pastel used to get the finishes of cat. B. Please notice that the final effect is different from the one created by the same lacquering through the glass, in particular when it comes to soft colours.

Mirrors

Gold and rose mirrors could have small imperfections due to the particular technical characteristics of the material. We recommend not to use them in damp areas. Clean only with a dry cloth.

Ceramic

The shown samples are part of the bigger slabs Sovet works with. The complete slab is visible in the corresponding folder. Clean using water and a small amount of neutral detergent. Avoid using detergents with wax and waxing products to avoid the formation of greasy layers.

Wood

Wood colours are indicative samples. Clean using a damp soft cloth.

Metals

Metals colours are indicative samples. Clean using a damp soft cloth.

Fabrics/Leathers/Fake leathers/velvets

Fabrics colours are indicative samples. For care and maintenance please refer to the instructions present in the corresponding folders and to the technical sheets provided by the manufacturers.

In case of further doubt please get in touch with the factory.









designer

Gianluigi Landoni

Gianluigi Landoni, graduated in architecture at Politecnico di Milano, in 1985 he participated to the founding of the design trend group Amalgama. From 1988 to 1990 project manager at Rodolfo Bonetto's studio. From 1991 partner of studio Progetica Design where he carries out research and development of industrial design, deepening the themes of product design. He has carried out his own professional activity as a consultant to "design oriented" companies in various productive sectors, and he founded with Rosaria Sofia Galli ALTROdesign multidisciplinary studio. At the same time he works on set-ups and realizations for furnishing companies in the hotel and commercial sector. He has also participated in exhibitions and competitions, receiving prizes and awards, not least the report to the 1991 edition of the Compasso d'Oro and subsequent Premio Compasso d'Oro in the 1998 edition. First prize Competition ADI/Expo 2015.

Gianluigi Landoni si è laureato in architettura al Politecnico di Milano. Nel 1985 ha fondato il gruppo di tendenza di design "Amalgama". Ha lavorato per lo studio Rodolfo Bonetto dal 1988 al 1990, e dal 1997 è partner dello studio Progetica Design, dove svolge un progetto di ricerca e sviluppo del design industriale e di prodotto. Ha anche fondato lo studio multidisciplinare ALTROdesign con Rosaria Sofia Galli. Dal 2001 svolge l'attività professionale in proprio come consulente ad aziende "design oriented" in vari settori produttivi, e si occupa parallelamente di allestimenti e realizzazioni per aziende di arredamento nel settore alberghiero e commerciale. Ha inoltre partecipato a numerose mostre e concorsi, ricevendo premi e riconoscimenti, non ultima la segnalazione all'edizione 1991 del Compasso d'oro e successivo Premio Compasso d'oro nell'edizione del 1998. È membro dell'Osservatorio permanente del design, dell'ADI Design Index e del Consiglio direttivo ADI Lombardia.



sustainability is made up of facts.

Sovet has always maintained a high attention to eco-compatibility since its birth in its birth in 1987, through the selection of raw materials and the study of production processes that have the least impact on the environment with the aim of creating long-lasting products.

Sovet ha sempre mantenenuto alta l'attenzione all'ecocompatibilità sin dalla sua nascita nel 1987, attraverso la selezione delle materie prime e lo studio di processi produttivi che abbiano il minimo impatto sull'ambiente con lo scopo di creare prodotti durevoli nel tempo.

photovoltaic systems



For its production processes Sovet uses energy coming directly from renewable sources. Thanks to its photovoltaic systems it is able to meet its own energy demand.

Per la sua produzione Sovet utilizza infatti energia derivante direttamente da fonti rinnovabili. Attraverso impianti fotovoltaici riesce a soddisfare il proprio fabbisogno energetico.



502695,549 kg emmission saved per year



2989 tree saved per year



165 barrel of oil saved per year

packiging



Sovet uses cardboard packaging with limited presence of oil-derivate.

Sovet usa imballi di cartone costruiti ad hoc con limitata presenza di derivati del petroli.



reduce plastic is an habits



To reduce the consumption of plastic and disposable bottles within its offices and production, Sovet created metal water bottles.

Per ridurre il consumo di plastica e bottiglie monouso all'interno dei suoi uffici e della produzione, Sovet ha creato delle borracce in metallo.

made in italy

The creative use of industrial processes, the use of raw materials of absolute quality and the scrupulous work of master craftsmen, allow Sovet to create high quality and 100% Made in Italy collections. Thanks to state-of-the-art industrial automation systems, Sovet is able to meet also large supply needs for contract spaces, always granting the highest quality standards. The company takes a continuous search path for materials, to create an offer of accessories complementing one another, furnishing different kinds of environments with the maximum customization possibility.

L'impiego creativo dei processi industriali, l'utilizzo di materie prime di assoluta qualità e le scrupolose lavorazioni eseguite da maestranze artigiane, permettono a Sovet di ottenere collezioni di alta qualità e 100% Made in Italy. Grazie a sistemi di automazione industriale all'avanguardia Sovet è in grado di soddisfare anche esigenze per grandi forniture destinate a spazi contract, sempre garantendo i più elevati standard qualitativi. Sovet intraprende un percorso di ricerca dei materiali per creare un'offerta di complementi che si integrino tra di loro, arredando varie tipologie di ambienti con la massima possibilità di personalizzazione.

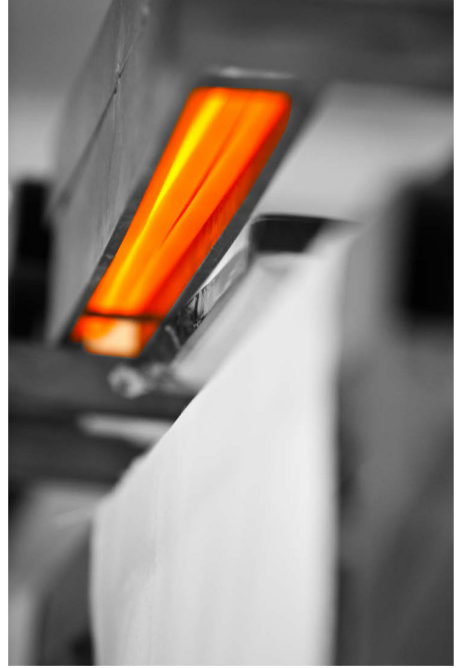
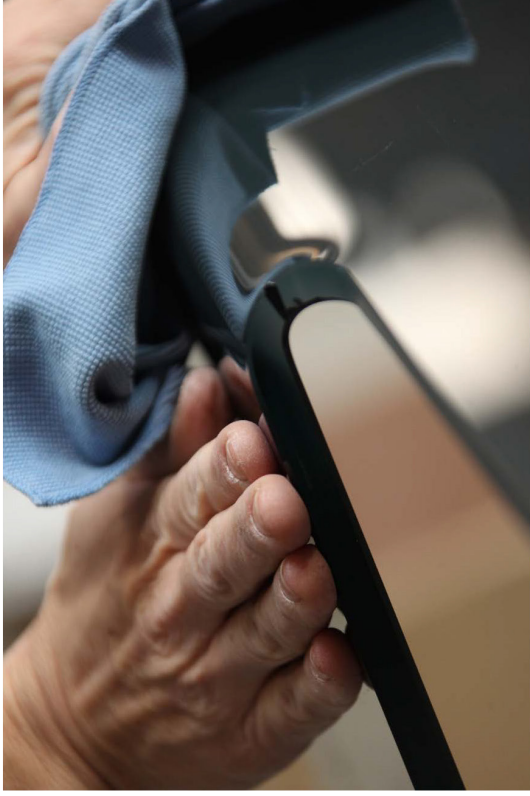

BARBICAN — RODOLFO DORDONI 2018

1—
6



A series of comfortable chairs suitable for all types of interiors. The design is based on a built-in padded seat, open or complete with armrests, the rigid polyurethane frame of which can be upholstered in fabric, leather, either totally or alternatively using the two materials that highlight the enveloping shape. Now also available in bonded hide leather with carefully and lovingly fashioned details. The seat can be matched with three types of base, composed of different materials such as wood or metal, in two versions, which make Barbican perfect for use in different contexts. The wooden base with linked curves is a perfect match for important tables. The metal one, with its modern design, is perfect both around a table or used with desks or Console tables in a home office. The tubular one is light and airy, ideal for contract projects where sturdiness and practicality are of primary importance. Barbican is a polyhedric design that redefines the chair in a contemporary key.



This symbol shows that the product has removable upholstery. Only qualified personnel can remove the upholstery of some of our products. If this information is pertinent, it will be included in the warnings section.



This symbol shows that the product is available on request in a fire resistant version that complies with the standards BS 5852 and TB 117-2013. The buyer is responsible for checking to make sure that the product is suitable and compliant with the requirements for the designated use and the current applicable laws and standards for the destination and use of the product.

DATASHEET
REGISTERED
DESIGN

IX.2021

FINISHES

NOTES

- ▶ **Fabric/leather upholstered versions have completely removable covers. We advise consulting experienced personnel to avoid damaging the product or the single components.**
- ▶ **Upholstery in bonded hide leather is NOT removable.**

WOOD BASES FINISHES

Solid wood stained:

eucalyptus - grey oak - graphite oak - black oak - walnut

METAL BASES FINISHES

Fixed bases

die-cast aluminium painted pewter colour / zinc - pipe metal painted pewter colour / zinc

Swivel version bases

die-cast aluminium with swivel mechanism glossy painted pewter colour or shiny aluminium

BONDED HIDE LEATHER FINISHES

ivory - black - dark brown - natural - mud green - dove grey

Molteni & C

2—

6

TECHNICAL INFORMATION

BACKREST SHELL STRUCTURE (FABRIC/LEATHER VERSIONS)

Compact polyurethane with polyurethane infill. Cover in cotton/polyester fibre.

SEAT SHELL STRUCTURE (CHAIR AND CHAIR WITH ARMRESTS - FABRIC/LEATHER VERSIONS)

Compact moulded polyurethane, with flexible cold-moulded polyurethane foam. Cover in cotton/polyester fibre.

SHELL STRUCTURE (BONDED HIDE LEATHER VERSIONS)

Compact moulded polyurethane, with flexible cold-moulded polyurethane foam. Cover in cotton/polyester fibre.

BASES

Laser-cut, welded and painted steel. Ferrules in non-slip plastic.

Solid ash wood stained in the colours of the Molteni range. Ferrules in non-slip plastic.

Die-cast aluminium elements assembled with thermosetting resins. Ferrules in non-slip plastic.

Die-cast shiny or painted aluminium; non-slip plastic ferrules.

REMOVABLE OUTER COVER

(See enclosed label, specific for the cover in question).

In the bonded hide leather version, the cover is not removable.



UPHOLSTERY
REMOVABLE FABRIC/LEATHER
BONDED HIDE LEATHER
VERSION UPHOLSTERY IS
NOT REMOVABLE



AVAILABLE IN FIRE-RESISTANT
VERSION TB117 AND BS6862

Fabric/leather versions

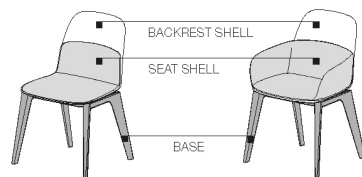

SWIVEL BASE

DATASHEET

REGISTERED
DESIGN

IX.2021

TECHNICAL INFORMATION

Bonded hide leather versions

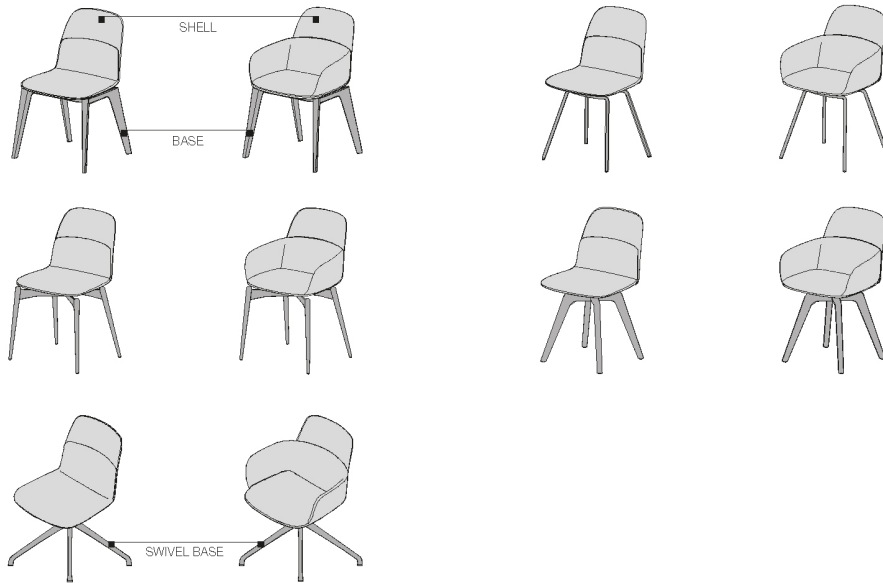

Molteni&C

3—
6

DIMENSIONS

When ordering, specify in this sequence:

- 1- Type of base and finish
- 2- Seat shell cover
- 3- Backrest shell cover

Fabric/leather versions

chair

BSE4

wood
base

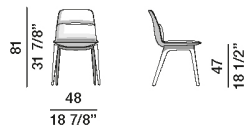

BSE1

wood
base

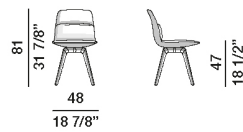

BSE2

base
aluminium
die-cast

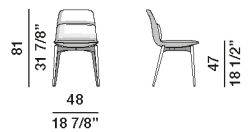

BSE3

base
pipe metal

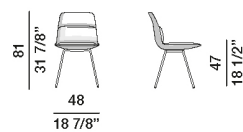

DATASHEET

REGISTERED
DESIGN

IX.2021

DIMENSIONS

Fabric/leather versions

chair with arms

BSB4

**wood
 base**

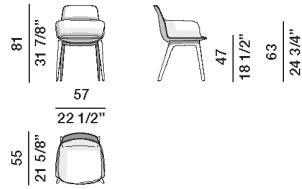

BSB1

**wood
 base**

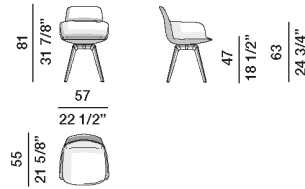

**base
 aluminium
 die-cast**

BSB2

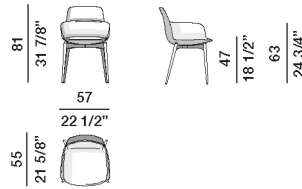

**base
 pipe metal**

BSB3

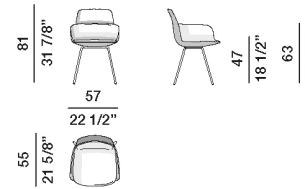

chair

BSE5

4-star swivel base

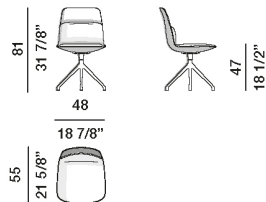

chair with arms

BSB5

4-star swivel base

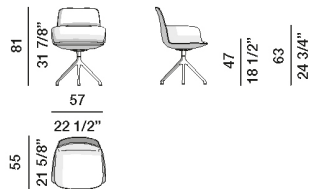

DATASHEET

REGISTERED
 DESIGN

IX.2021

DIMENSIONS

Bonded hide leather versions

chairs

BSE4

wood base/
bonded hide leather

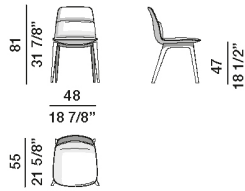

BSE1

wood base/
bonded hide leather

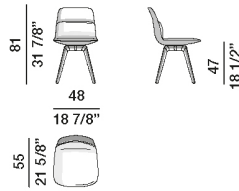

BSE2

base
aluminium die-cast/
bonded hide leather

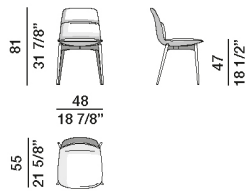

BSE3

base
pipe metal/
bonded hide leather

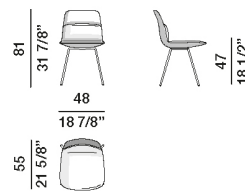

BSE5

4-star swivel
die-cast base/
bonded hide leather

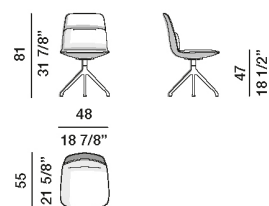

Molteni & C

5 —
6

DATASHEET
REGISTERED
DESIGN

IX.2021

moltenigroup.com

Dimensions in centimeters and inches. The right to discontinue and make changes is reserved. This information is based on the latest product information available at the time of printing.

DIMENSIONS

Bonded hide leather versions

chairs with arms

BSB4
 wood base/
 bonded hide leather

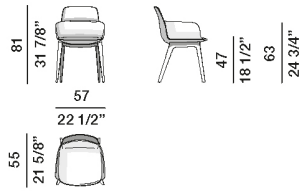

BSB1
 wood base/
 bonded hide leather

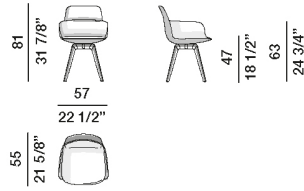

BSB2
 base
 aluminium die-cast/
 bonded hide leather

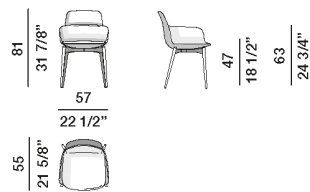

BSB3
 base
 pipe metal/
 bonded hide leather

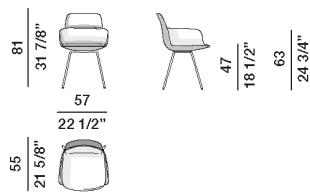

BSB5
 4-star swivel
 die-cast base/
 bonded hide leather

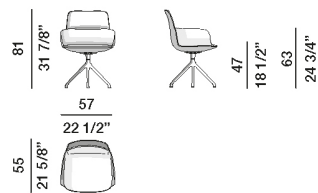

DATASHEET

REGISTERED
 DESIGN

IX.2021

FLOS

F2500000 Chrome

Frisbi

Designed by Achille Castiglioni, 1978



Halogen - 105W

Suspension lamp providing direct, diffused and reflected light. Opaline polymethylmethacrylate (PMMA) injection-molded diffuser plate suspended by three fine steel cables. Polished, nickel-plated, and zapon-varnished stamped sheet metal reflector painted gloss-white inside. Black painted, injection-molded ABS ceiling fitting and rose.

Are you a professional and your project needs consulting and support?

[BOOK AN APPOINTMENT](#)

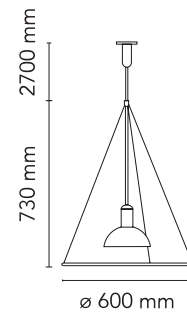

Main specifications

EAN	8059607016206
Mounting	Suspension
Environment	Indoor dry location
Light source type	Bulb
Lamp category	Halogen
Lamp holder	E27
Ilcos	HSGSR
Number of heads	1
Power (W)	105

Physical

Colour	Chrome
Cord length (mm)	2700
Net weight (kg)	2.65
Package height (cm)	17
Package width (cm)	66
Package length (cm)	66
Package volume (m3)	0.07
IP	20
IP external	20

Download

[Mounting instructions](#) PDF

[Spare Parts](#) PDF

Photometric Files

[LDT / IES](#) LDT

Technical Drawings

[2D](#) ZIP

[3D](#) ZIP

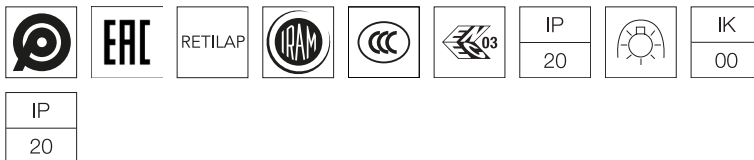

Schematic light drawing

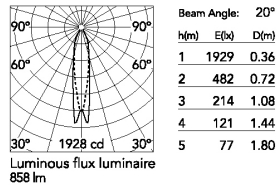

Photometric

Lighting type	Direct
Light distribution	Roto symmetric

Electrical

Insulation class	II
Frequency (Hz)	50/60
Main voltage (Vac)	220-250
Cord length (mm)	2700
Batteries inside	No
Charging min time	No

Bulbs

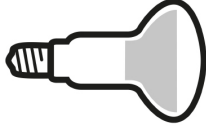

NOT INCLUDED

RF31458

LED Reflector Frosted Lamp E27
13W 2700K R80 Dimmable

Spare Parts



RF00862

Reflector



RF01439

Grid support with stem



RF05806

Plexiglass diffuser



RF06823

Frisbi steel wires (3 pieces)



RF2500100

Complete ceiling rose assembly



RF2500200

New version lamp holder



RF29648

2x1 2.7 mt black electrical cable

LA ISLA by Note Design Studio, 2017

banco / bench / ilot

SANCAL 



EXPLICACION DEL MODELO

Un acogedor refugio para navegantes...

Diseñada por el aclamado estudio sueco **Note**, **La Isla** es un asiento para colectividades que responde a la proliferación de lo que Marc Augué denominara "no-lugares".

Cada vez con más frecuencia nos vemos expuestos a zonas de tránsito; no-lugares generalmente inhóspitos y poco afectivos. **Sancal** ha confiado en el saber hacer del estudio sueco, con la intención de mejorar la experiencia de quienes viajan, ya sea por trabajo o placer.

Note ha creado un espacio de paso que permite usos simultáneos sin interferencias. Un lugar para compartir con desconocidos, pero respetuoso con nuestra privacidad; aislado, pero no excluyente.

La Isla es un banco con identidad, de amplias proporciones, generoso y amable. Perfecto para tomar un respiro en la recepción de un hotel o en la zona de espera de un aeropuerto.

Su onrada silueta y curvas sinuosas crean una sentada tierna y sedosa.

La familia consta de 3 medidas y una extensa gama de tejidos. El zócalo está disponible en todos los colores de nuestra carta de lacados.

Opcionalmente, es posible incorporar enchufes y conectores USB-A + C con una amplia variedad de clavijas. En cada referencia de la tarifa tiene indicada la cantidad, posición y opciones disponibles.

La clavija de conexión a la red eléctrica viene definida por el enchufe internacional seleccionado, en caso de seleccionar solo USB, por favor, indique la clavija deseada.

Las mesitas auxiliares amplían la oferta. Al igual que en los asientos, lo más característico de ellas son las líneas curvas. Sus 3 alturas y la forma de sus sobres, redondo u ovalado hacen que puedan interactuar entre ellas.

Las bases, con forma de aspa, recuerdan formalmente al respaldo de los bancos, sin duda el elemento distintivo común a toda la familia. Los sobres son de cristal fumé por lo que dejan entrever la tan característica base, la cual puede ser lacada en todas las opciones de laca de nuestra carta.

DESCRIPTION

An enticing destination in a sea of nothingness...

Designed by the acclaimed Swedish studio **Note**, **La Isla** is a seating programme for social areas – vast seas of inhospitable and unwelcoming space that Marc Augué has dubbed "non-places".

Sancal turned to **Note** to provide some relief for weary travellers. They came up with **La Isla** as a solution. Its seductive curves and soft upholstery call out to all those navigating a lobby, desperately seeking refuge.

Once installed on **La Isla** they will not be disappointed. The upholstery is just as comfortable as it looks with generous proportions and soft materials. A place to share with strangers while respecting their privacy; isolated but not excluded.

La Isla comes in three different sizes and a selection of fabrics from **Sancal's** collection. The plinth can be lacquered in any of the colours as per the chart in the price list.

A range of electrical sockets are available, including USB-A + C; please refer to the price list for the positions and options. The plug to connect the Isla is defined by the socket, apart from the USB-A + C version where the required plug type must be specified in the order.

The occasional tables complete the range and continue with the same design language based on curves. Three heights are available, and the tabletops are available in round or oval versions, allowing them to interact with each other.

The fumé glass tops enable us to view the bases, shaped like blades as a nod to the the benches' backs, they can be lacquered as per our colour chart.

CARACTERISTIQUES

Un refuge accueillant pour les voyageurs ...

Dessiné par le très salué studio suédois **Note**, **La Isla** est une solution d'accueil pour les collectivités qui répond à la prolifération de ce que l'anthropologue Marc Augé appellera des «non-lieux».

De plus en plus souvent nous sommes confrontés à des zones de transit, des non-lieux généralement inhospitaliers et peu affectifs. **Sancal** a cru au savoir-faire de l'étude suédoise, dans l'intention d'améliorer l'expérience de ceux qui voyagent, pour le travail ou pour le simple plaisir.

Objectif atteint ! **Note** a créé un espace de passage qui permet des utilisations simultanées sans interférence. Un endroit à partager avec des inconnus, mais respectant notre confidentialité, isolé mais pas exclu.

La Isla est un ilot central avec une identité forte, de grandes dimensions, généreux et amical. Parfait pour faire une pause à la réception d'un hôtel ou dans la zone d'attente d'un aéroport.

Sa silhouette arrondie aux courbes sinusoïdales crée une assise tendre et soyeuse.

La famille comporte 3 dimensions et une gamme étendue de revêtements. Le socle est disponible dans toutes les finitions de notre carte de couleurs.

En option il est possible d'incorporer des prises électriques et connexions USB A + C avec une grande amplitude de fiches. Dans chaque référence du tarif il est indiqué la quantité, la position et les options disponibles.

La fiche de connexion au réseau électrique est définie par la prise internationale sélectionnée, dans le cas de ne choisir que des USB, merci d'indiquer la fiche désirée.

Les tables auxiliaires rendent l'offre plus importante. Comme pour les assises, le plus caractéristique sont les lignes courbes. Les 3 hauteurs et la forme des plateaux, ronds ou ovales font qu'elles peuvent interagir entre elles.

Les bases en forme de croix rappellent formellement les dossiers des ilots centraux, sans aucun doute l'élément distinctif commun à toute la famille. Les plateaux sont en verre fumé, laissant entrevoir la si caractéristique structure, qui peut être laquée dans toutes les laques de notre palette.

FIRMEZA / FIRMNESS / FERMETÉ

SUAVE
SOFT
DOUX

--	--	--	--	--

FIRME
FIRM
FERME

IMPORTANTE

Los tejidos aptos pertenecen a los muestrarios referenciados en la tabla.

El banco no requiere montaje.

Para la Isla con kit la toma de corriente debe estar situada debajo del banco.

La base y la tapa de la mesa se sirven individualmente y requieren montaje. Incorpora instrucciones de montaje.

Servicio RAL disponible para este producto. Por favor, consulta el apartado "Colores RAL" en la sección de "Otros acabados", al final de esta tarifa.

IMPORTANT

This product is only available in the fabrics listed in the table.

The bench does not require assembly.

The electric Isla must be positioned over a floor mounted socket.

The table top and base are packaged individually and require assembly as per the instructions included with the product.

Match to RAL service available for this product. Please consult the "RAL Colours" in the "Other finishes" section at the end of this price list.

IMPORTANT

Les tissus aptes pour ces modèles sont dans les liasses référencées dans le tableau.

Le ilot ne requiert pas de montage.

Pour la Isla avec kit, la prise de courant doit être placée en dessous de la banquette.

Tables: Les plateaux et les bases sont livrés emballés séparément (voir instructions de montage).

Service RAL disponible pour ce produit. Merci de consulter la partie "Couleurs RAL" dans la section "Autres finitions", à la fin du tarif.

CARACTERISTICAS TECNICAS

TELA

- Funda textil: tapizado fijo.
- Estructura de asiento: madera maciza preparada con cinchas elásticas de 80mm, recubierta de espuma CMHR 35kg y CMHR 30kg y fibra H100gr.
- Estructura de respaldo: tablero de partículas recubierto de espuma CMHR 30kg. y fibra H100gr.
- Zócalo: DM lacado extra mate.

Kit eléctrico

- Longitud de cable: 1,3 metros.
- USB A + C 5A. En caso de rotura o avería, posibilidad de repuesto con cambio fácil, sin necesidad de desmontar el asiento ni desconectarlo de la toma eléctrica. Consulte con nuestro departamento comercial para solicitar un repuesto.
- Opción de enchufes internacionales.
- Carcasa color negro.

Mesas

- Tapa: cristal templado 10mm acabado gris fumé.
- Base: estructura de DM acabado lacado extra mate, con tacos deslizantes.

PIEL

- No se fabrica.

TECHNICAL SPECIFICATIONS

FABRIC

- Fixed textile cover.
- Seat structure: solid wood fitted with 80mm elastic webbing, covered in CMHR 35kg and CMHR 30kg foam and H100g fibre.
- Back structure: particleboard covered in CMHR 30kg foam and H100g fibre.
- Plinth: Extra matte lacquered MDF.

Electric socket system

- Cable length: 1,3m.
- USB A + C 5A. Can be replaced easily if broken, please request a quote from our sales department.
- Range of international sockets available.
- Black finish.

Tables

- Top: 10mm grey fumé tempered glass.
- Base: MDF extra matte lacquered base with glides.

LEATHER

- This product is not available in leather.

CARACTERISTIQUES TECHNIQUES

TISSU

- Housse textile fixe, non déhoussable.
- Structure d'assise: bois massif préparé avec des sangles élastiques de 80mm et recouvertes de mousse CMHR 35kg et CMHR 30kg, et fibre H100gr.
- Structure de dos: panneau de particules recouvert de mousse CMHR 30kg, et fibre H100gr.
- Socle: Médium laqué extra mat.

Kit électrique

- Longueur du câble: 1,30 mètres.
- USB A + C 5A. En cas de casse ou de panne, possibilité de réparation avec échange facile, sans démontage de l'assise, et sans déconnexion de la prise de courant. Merci de contacter le service commercial pour tout échange.
- Option prises de courant internationales.
- Boîtier de couleur noir.

Tables

- Plateau: verre trempé de 10mm, gris fumé.
- Structure: médium laqué extra mat, patin antiglisses.

CUIR

- Ne se fait pas en cuir.

	MUESTRARIOS POR SERIES / SAMPLE BOOK BY SERIES / LIASSE PAR SERIE										
	S-2	S-3	S-4	S-5	S-6	S-7	S-8	S-9	S-10	S-11	S-12
TEJIDOS APTOS COMPATIBLE FABRICS TISSUS COMPATIBLES	ATLANTIC (112)	CURA MICA STEP (108) STEP M. (108) SILVERTEX	101 FACET 2 (107.2)	122 128 129 133 BLEND CADET CYBER	115 117 119 ATLAS OMEGA REMIX 3	116 124 127 130 131 GALAXY GLOW	COMFORT + STEELCUT 2 STEELCUT T. 3 PLANUM	MOSAIC 2 PLECTO SPRINKLES UNIFORM M.	DROP RAZZLE DAZZLE HARALD 3	CODA 2 SISU	GENTLE 2

LA ISLA by Note Design Studio, 2017

LA ISLA BANCO CON KIT ELECTRICO

El kit está compuesto de 2 ó 4 puntos de conexión según referencia. La ubicación de los puntos de conexión está identificada en la imagen inferior por letras. Indique para cada punto de conexión el tipo que desee que lleve instalado, puede seleccionar entre bases de enchufe de distintos continentes o usb.

LA ISLA BENCH WITH AN ELECTRIC KIT (OPTIONAL)

The kit includes 2 or 4 connection points depending on reference. The connection points positionings are identified by letters as the image below. You must specify the type you want to be installed for each connection point. Select between international socket options or USB charging socket (TUF).

LA ISLA AVEC KIT ÉLECTRIQUE

Le kit électrique composé de 2 ou 4 points de connexion selon la référence. L'emplacement des points de connexion est identifié sur l'image inférieure par des lettres. Merci d'indiquer pour chaque point de connexion le type demandé (pour son installation). Vous pouvez sélectionner entre différentes base de prise des différents continents ou Usb.

UBICACIÓN Y CANTIDAD DE PUNTOS DE CONEXION (A, B, C, D) POR REFERENCIA.
LOCATION AND AMOUNT OF POWER SOCKETS (A, B, C, D) BY REFERENCE.
EMPLACEMENT ET QUANTITÉ DES POINTS DE CONNEXION (A, B, C, D) PAR RÉFÉRENCE.

314.10.VRH.KIT

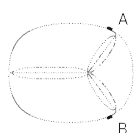

314.10.TTH.KIT

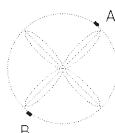

314.10.Z2RH.KIT

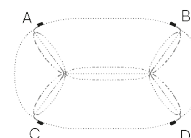

OPCIONES DE PUNTO DE CONEXION / POWER SOCKET OPTIONS / OPTIONS DE POINTS DE CONNEXION



SELECCIONE EL ENCHUFE / SELECT SOCKET / SÉLECTIONNE LE PRISE



EU



AU



GB



US/JP*



USB A + C

* No disponemos de certificación para Japón.
Does not meet Japanese certification.
Ne répond pas à la certification du Japon.

La clavija de conexión a la red eléctrica viene definida por el enchufe internacional seleccionado, en caso de seleccionar solo USB, por favor, indique la clavija deseada.

The plug to connect La Isla is defined by the socket, apart from the USB-A + C version where the required plug type must be specified in the order.

La fiche de connexion au réseau électrique est définie par la prise internationale sélectionnée, dans le cas de ne choisir que des USB, merci d'indiquer la fiche désirée.

EJEMPLO DE PEDIDO DE ISLA BANCO CON KIT ELECTRICO / EXAMPLE OF ISLA BENCH ORDER WITH SOCKETS / EXEMPLE D'ORDRE DE ISLAN ILOT AVEC KIT ÉLECTRIQUE

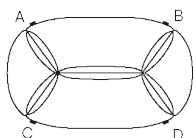

1 La Isla banco 257x 154 c/kit, ref. 314.10.Z2RH.KIT con: 2 base enchufe en puntos de conexión A y D
2 usb en puntos de conexión B y C.

1 La Isla bench 257x 154 w/kit, ref. 314.10.Z2RH.KIT with: 2 socket in power sockets A & D
2 usb in power sockets B & C.

1 La Isla ilot 257x 154 avec kit, ref. 314.10.Z2RH.KIT avec: 2 prise de courant en points de connexion A et D
2 usb en points de connexion B et C.

LA ISLA by Note Design Studio, 2017

banco / bench / ilot

SANCAL 

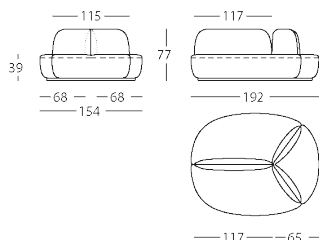

314.10VRH

LA ISLA BANCO 192X154
LA ISLA BENCH 192X154
LA ISLA ILOT 192X154

2,93 m³ / 1 Pack. / 112,0 kg

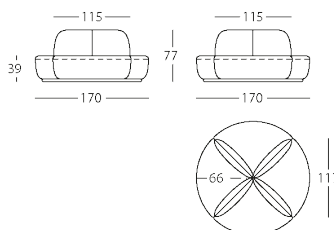

314.10TTH

LA ISLA BANCO D170
LA ISLA BENCH D170
LA ISLA ILOT D170

2,75 m³ / 1 Pack. / 114,0 kg

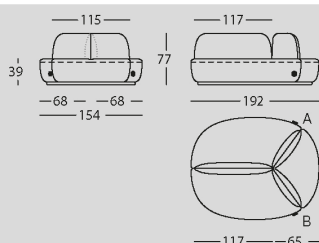

314.10VRH.KIT

LA ISLA BANCO 192X154 C/KIT
LA ISLA BENCH 192X154 W/KIT
LA ISLA ILOT 192X154 AVEC KIT

2,93 m³ / 1 Pack. / 112,0 kg

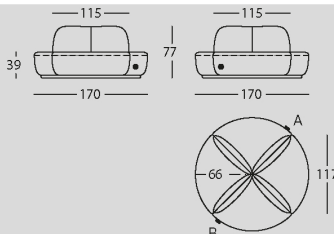

314.10TTH.KIT

LA ISLA BANCO D170 C/KIT
LA ISLA BENCH D170 W/KIT
LA ISLA ILOT D170 AVEC KIT

2,75 m³ / 1 Pack. / 114,0 kg

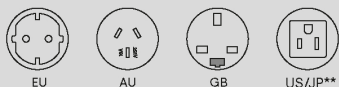

OP. BASE ENCHUFE
OP. SOCKET
OP. PRISE DE COURANT

- m³ / - Pack. / - kg



OP. USB
OP. USB
OP. USB

- m³ / - Pack. / - kg

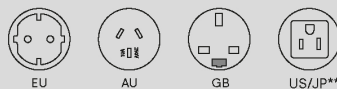

OP. BASE ENCHUFE
OP. SOCKET
OP. PRISE DE COURANT

- m³ / - Pack. / - kg



OP. USB
OP. USB
OP. USB

- m³ / - Pack. / - kg

Kit eléctrico con dos puntos de conexión A y B; indique la opción deseada para cada una de ellos. La clavija de conexión a la red eléctrica viene definida por el enchufe internacional seleccionado, en caso de seleccionar solo USB, por favor, indique la clavija deseada.

Electrical kit with two connection points: A and B. Please state the desired option for each socket. The plug to connect La Isla is defined by the socket, apart from the USB version where the required plug type must be specified in the order.

Kit électrique avec 2 points de connexion A et B; spécifier sur le bon de commande la option pour chacun d'eux. La fiche de connexion au réseau électrique est définie par la prise internationale sélectionnée, dans le cas de ne choisir que des USB, merci d'indiquer la fiche désirée.

** No disponemos de certificación para Japón / Does not meet Japanese certification / Ne répond pas à la certification du Japon.

LA ISLA by Note Design Studio, 2017

banco / bench / ilot

SANCAL 

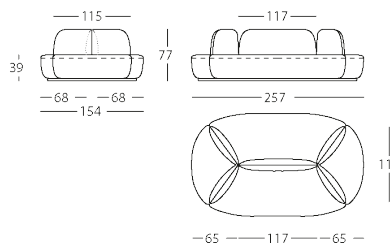

314.10.Z2RH

LA ISLA BANCO 257X154
LA ISLA BENCH 257X154
LA ISLA ILOT 257X154

3,87 m² / 1 Pack. / 160,0 kg

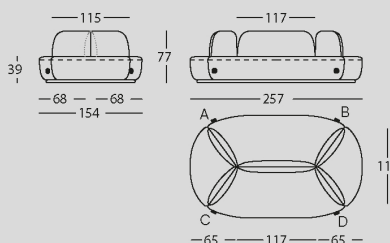

314.10.Z2RH.KIT

LA ISLA BANCO 257X154 C/KIT
LA ISLA BENCH 257X154 W/KIT
LA ISLA ILOT 257X154 AVEC KIT

3,87 m² / 1 Pack. / 160,0 kg



EU

AU

GB

US/JP**

OP. BASE ENCHUFE
OP. SOCKET
OP. PRISE DE COURANT

- m² / - Pack. / - kg



OP. USB
OP. USB
OP. USB

- m² / - Pack. / - kg

Kit eléctrico con dos puntos de conexión A y B: indique la opción deseada para cada una de ellos. La clavija de conexión a la red eléctrica viene definida por el enchufe internacional seleccionado, en caso de seleccionar solo USB, por favor, indique la clavija deseada.

Electrical kit with two connection points: A and B. Please state the desired option for each socket. The plug to connect La Isla is defined by the socket, apart from the USB version where the required plug type must be specified in the order.

Kit électrique avec 2 points de connexion A et B: spécifier sur le bon de commande la option pour chacun d'eux. La fiche de connexion au réseau électrique est définie par la prise internationale sélectionnée, dans le cas de ne choisir que des USB, merci d'indiquer la fiche désirée.

** No disponemos de certificación para Japón / Does not meet Japanese certification / Ne répond pas à la certification du Japon.

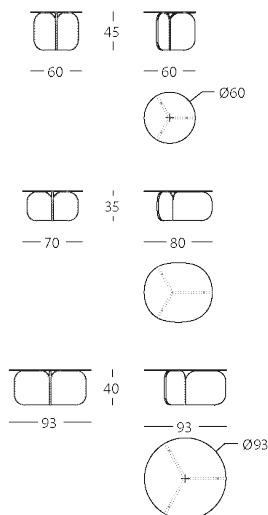

314.71.D60X45

LA ISLA MESITA D60X45
LA ISLA OCCASIONAL TABLE D60X45
LA ISLA TABLE D60X45

0,16 m² / 2 Pack. / 15,9 kg

314.71.80X70X35

LA ISLA MESITA 80X70X35
LA ISLA OCCASIONAL TABLE 80X70X35
LA ISLA TABLE 80X70X35

0,20 m² / 2 Pack. / 21,3 kg

314.71.D93X40

LA ISLA MESITA D93X40
LA ISLA OCCASIONAL TABLE D93X40
LA ISLA TABLE D93X40

0,35 m² / 2 Pack. / 27,4 kg

ACABADOS / FINISHES / FINITIONS

ZOCALO / PLINTH / SOCLE

BASE MESA / BASE TABLE

LACADO EXTRA MATE / EXTRA MATTE LACQUER / LAQUÉ EXTRA MAT



TAPA MESA / TABLE TOP / PLATEAU TABLE

CRISTAL / GLASS / VERRE



210 FUMÉ

MILANO 1932



PINECONE LARGE

Paola Navone, 2016

Pinecone is a suspension and table lamp. The diffuser is manufactured using the ancient caged blown glass technique: the glass maker blows the molten glass blob into a metal cage, which only partly contains the blob's natural expansion. In this way, the glass surface is partly trapped by and partly escapes the cage, generating an impression of tension as the object struggles to free itself from its harness; the cage is further enriched by the galvanic treatment that makes it look glossy and brilliant. The transparent version, in particular, reveals a two-fold structure that multiplies the scenic effect, while the metal cage pattern projects kaleidoscopic shade effects on the surrounding surfaces. On the contrary, in the white version the glass delicately envelops the cage surface and enhances its geometric pattern, generating an elegant and visually pleasing diffused light. The lighting fixture makes a highly appealing and striking impact either switched on or off.

Suspension lamp with diffused and dimmable light. Enclosed diffuser made of frosted blown glass. Cage and base made of chromed metal. Steel suspension cables. Transparent power cable. Bulb not included.

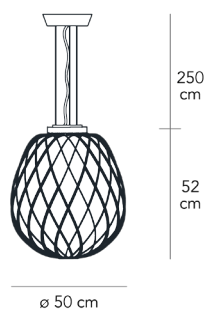

MADE IN

IT

MATERIAL DESCRIPTION

glass, galvanized metal

ALIMENTATION CABLE

Transparent

COLOR DESCRIPTION SKU

white, chrome

DIMMER

Dimmable

GROUP TENSION

Bulb

CERTIFICATIONS

CE ENEC IP20

ENERGY CLASS

A++ G

COLOR

LIGHT SOURCE

1x max 116W E27

Molteni & C

GATWICK — RODOLFO DORDONI 2019

1—
3



This table, designed by Milanese architect Rodolfo Dordoni, takes the name of London's Gatwick airport, one of the busiest in the world. A hub where cosmopolitan travellers meet every hour of the day and night on their way in or out of the U.K. capital, much like a table where people meet for dinner. The aluminium frame supports elegant rectangular or oval tops of different sizes enriched with wood or marble, selected from the Molteni&C collection.

DATASHEET

REGISTERED
DESIGN

IX.2021

moltenigroup.com

Dimensions in centimeters and inches. The right to discontinue and make changes is reserved. This information is based on the latest product information available at the time of printing.

FINISHES

STRUCTURE FINISHES

glossy zinc
black chrome
pewter colour (satin finish)

* WOODEN TOP FINISHES

eucalyptus
graphite oak
walnut

MARBLE TOP FINISHES

orient grey
Sahara noir
calacatta gold

★

Tables with wood top while stocks last. Check with the Molteni&C Sales Office for availability.

TECHNICAL INFORMATION

WOOD TOP

Shaped MDF panel covered with wood veneer in eucalyptus (*Eucalyptus Globulus*), oak (*Quercus*) or walnut (*Juglans Nigra*).

MARBLE TOP

Marble in the range of finishes specific for the product.

STRUCTURE

In extruded aluminium, bent to form the leg, painted in a range of finishes specific for the product. Joint connects the leg with the aluminium crosspiece. Fixing bracket between structure and table top in metal with painted epoxy finish. Plastic feet with felt pads.

UNDERTOP

Chipboard panel covered with melamine facing.

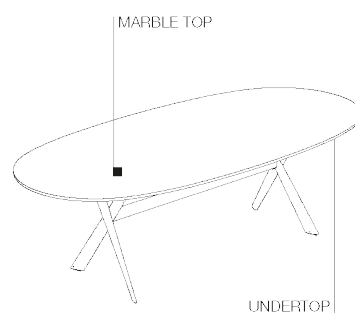
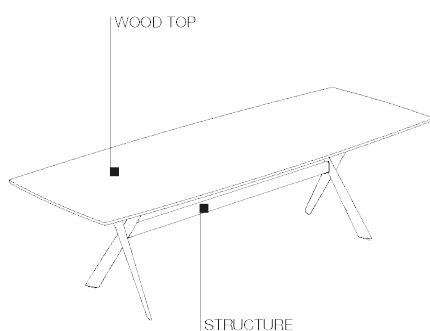

DATASHEET

REGISTERED
DESIGN

IX.2021

DIMENSIONS

wood tables

GTF22/10

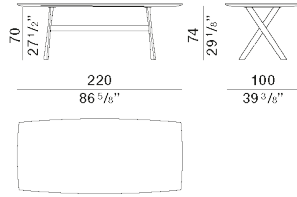

pewter colour structure glossy zinc/ black chrome structure

GTF26/10

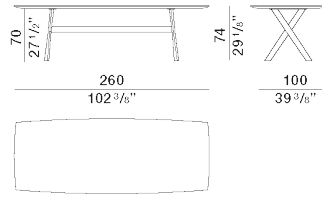

pewter colour structure glossy zinc/ black chrome structure

GTF30/10

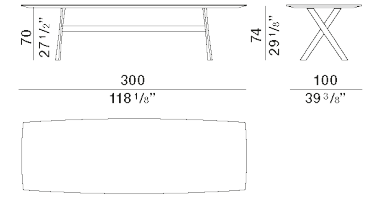

pewter colour structure glossy zinc/ black chrome structure

marble tables

GTO21/10

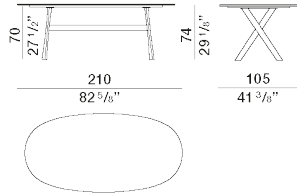

pewter colour structure glossy zinc/ black chrome structure

GTO24/12

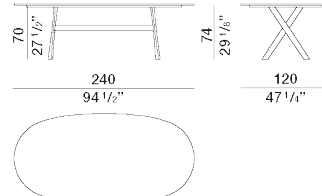

pewter colour structure glossy zinc/ black chrome structure

GTO28/13

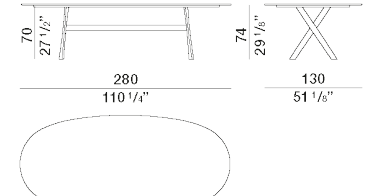

pewter colour structure glossy zinc/ black chrome structure

marble console

GTC15/60

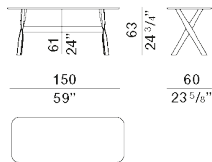

pewter colour structure glossy zinc/ black chrome structure

Molteni & C

3
 0

DATASHEET

REGISTERED
 DESIGN

IX.2021

Molteni & C

DEVON — RODOLFO DORDONI 2020

1—
4



Four chairs, two bucket armchairs, a pouf, one bar stool with backrest and another without and a complementary coffee table, these are the components of the Devon collection. All the frames are made of solid ash with eucalyptus, walnut, graphite oak, grey or black oak veneers. Seats and backrests upholstered in fabric or leather chosen from the Molteni&C range. The table top is available in various types of marble. The strong feature of the solid wooden frame balances the fluid line of the backrests, blending ergonomics and elegance to create refined and comfortable chairs. Each element of the Devon collection expresses the value of craftsmanship, which is manifest in the way the top quality materials are processed, with details expressed with dedication and passion.



This symbol shows that the product has removable upholstery. Only qualified personnel can remove the upholstery of some of our products. If this information is pertinent, it will be included in the warnings section.



This symbol shows that the product is available on request in a fire resistant version that complies with the standards BS 5852 and TB 117-2013.

The buyer is responsible for checking to make sure that the product is suitable and compliant with the requirements for the designated use and the current applicable laws and standards for the destination and use of the product.

DATASHEET

REGISTERED
DESIGN

IX.2021

FINISHES

BASE FINISHES

solid wood stained:

eucalyptus - grey oak - graphite oak - black oak - walnut

SMALL TABLE TOP FINISHES

marble:

silver dune - silver wave - green alpine - Sahara noir - calacatta gold

TECHNICAL INFORMATION

STRUCTURE

In solid wood stained. Feet in non-slip plastic.

SEAT (SMALL ARMCHAIRS - CHAIRS - POUF - STOOL)

Internal structure is a solid Firwood (Picea abies) frame and chipboard, with elastic straps. Padding in variable density high-resistance foam polyurethane. Cover in bonded velveteen.

BACKREST (SMALL ARMCHAIRS, CHAIRS AND STOOL)

Internal structure in Polimex (composite polyester/polyurethane material) covered with variable density high-resistance polyurethane foam. Cover in bonded velveteen.

SMALL TABLE TOPS

Marble from the Molteni&C collection, according to the model-specific price list.

REMOVABLE OUTER COVER

(See enclosed label, specific for the cover in question).



AVAILABLE IN FIRE-RESISTANT
VERSION TB117 AND BS5852

SMALL ARMCHAIRS

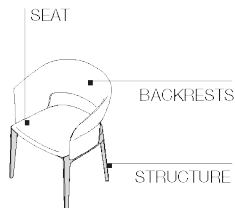

CHAIRS

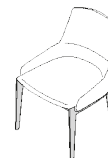
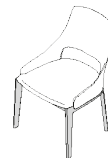

POUF



SMALL TABLE



STOOLS

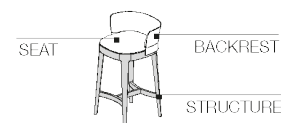

DATASHEET

REGISTERED
DESIGN

IX.2021

DIMENSIONS

Molteni & C

3 —
 4

chair

DSD1

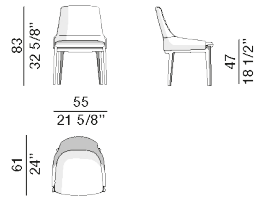

chair

DSD2

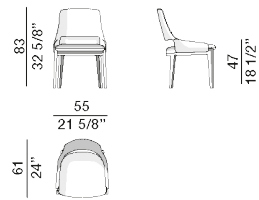

chair with arms

DSB1

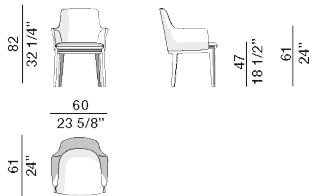

chair with arms

DSB2

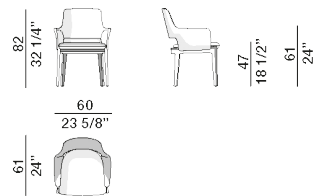

small armchair

DPL1

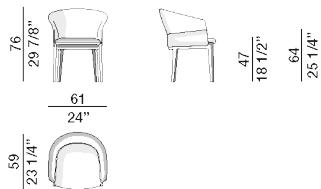

small armchair

DPL2

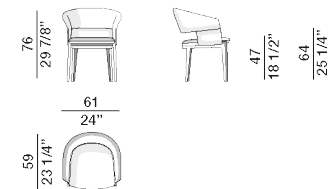

DATASHEET

REGISTERED
 DESIGN

IX.2021

DIMENSIONS

pouf

DPO1

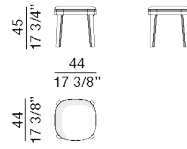

stool

DSG1

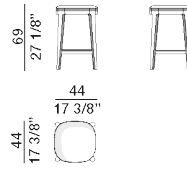

stool

DSG2

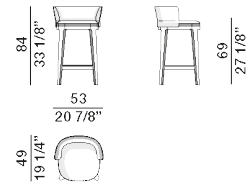

Molteni & C

4 —

4

small table

DTV1

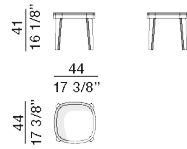

DATASHEET

REGISTERED
DESIGN

IX.2021

moltenigroup.com

Dimensions in centimeters and inches. The right to discontinue and make changes is reserved. This information is based on the latest product information available at the time of printing

Usinagens para suportes na porta de madeira

Air pode ser fornecida com suportes para caneco e para braço para inserir, respectivamente, na porta e no móvel. Os suportes permitem uma maior facilidade na instalação da dobradiça e ajudam a cobrir imperfeições e eventuais erros de usinagem no móvel.

O suporte para braço, colado dentro do painel, restaura sua compactação, permitindo o uso da dobradiça Air também em espessuras reduzidas. Aconselhamos utilizar uma cola de poliuretano monocomponente de baixa expansão, adequado para colagem de madeira e metal.

Além disso, para facilitar a aderência da cola, também é possível inserir dois parafusos 3,5x20 (não fornecidos) no fundo do suporte.

Os suportes estão disponíveis em duas cores, para dobradiças niqueladas e titânio.

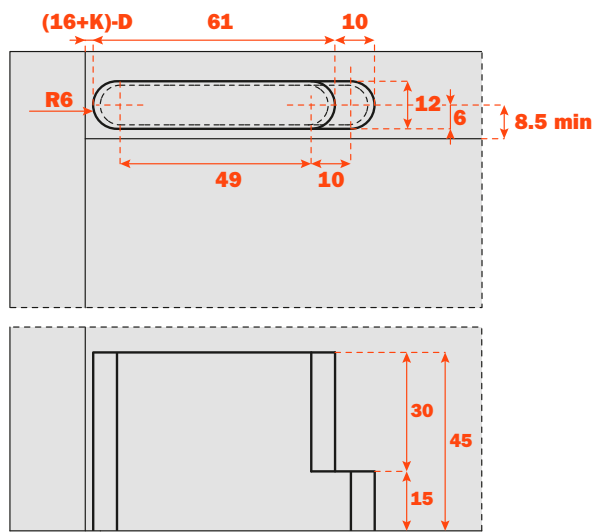
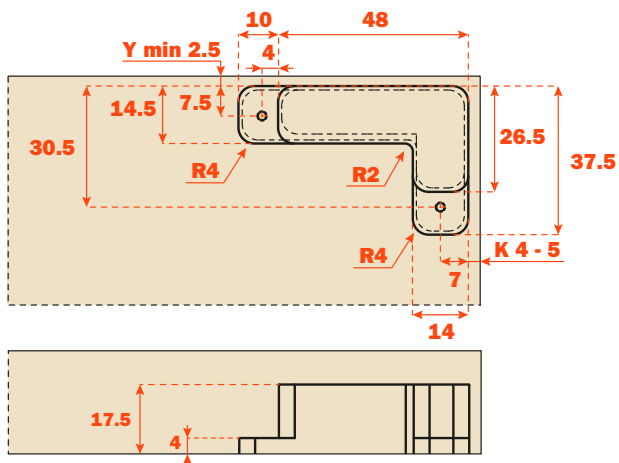
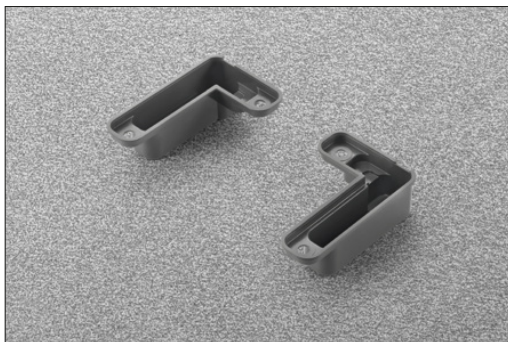

Cálculo das distâncias para inserção dos suportes para braço.

$$A = B + C$$

$$B = A - C$$

$$C = A - B$$

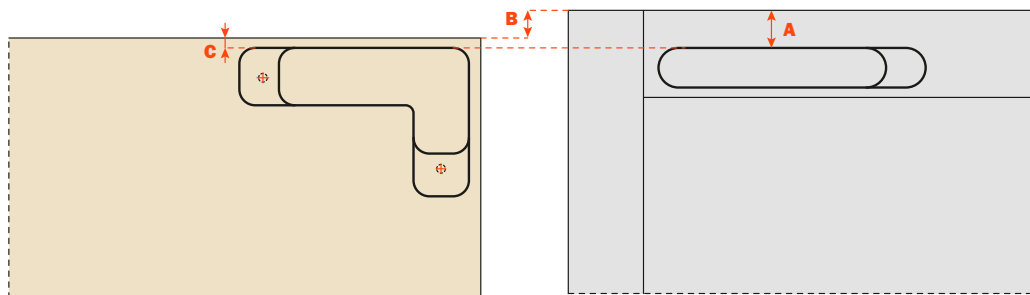

Air - Usinagens para suportes no quadro de alumínio



Usinagem no quadro de alumínio DEL6LP300_.

Dimensão do perfil 26x26 mm.

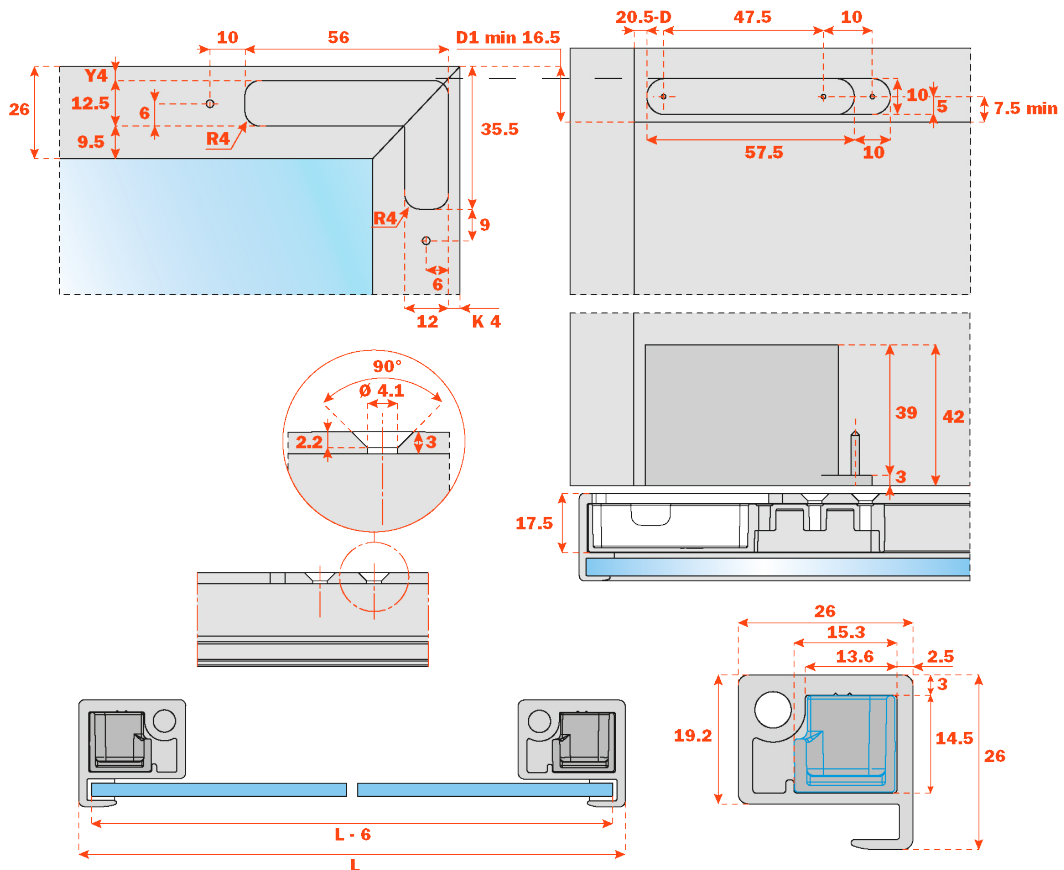

Cálculo das distâncias para inserção dos suportes para braço.

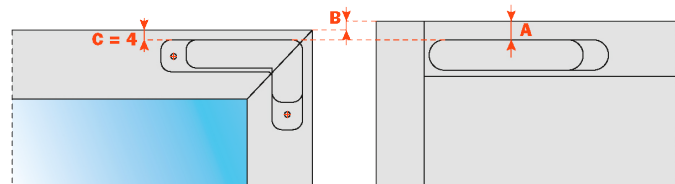

$$A = B + 4$$

$$B = A - 4$$



Usinagem no quadro de alumínio DEL9LP300_.

Dimensão do perfil 26x19 mm.

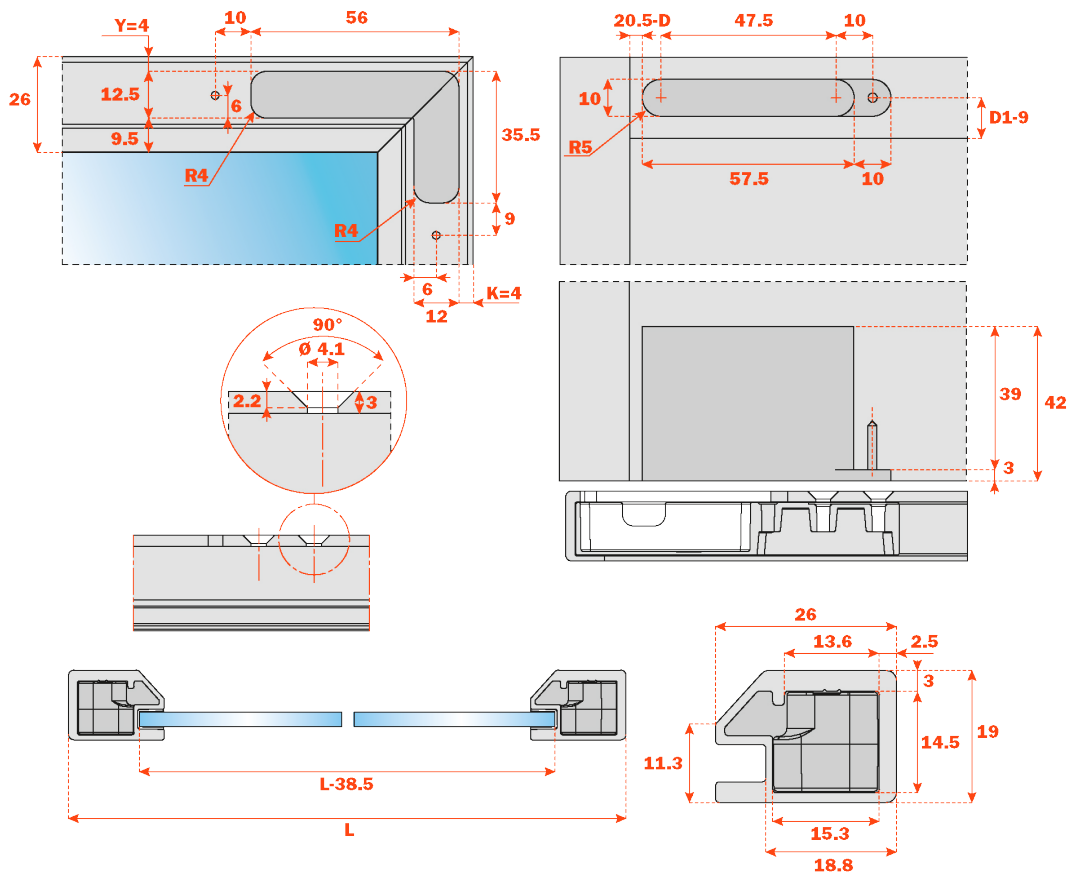

Cálculo das distâncias para inserção dos suportes para braço.

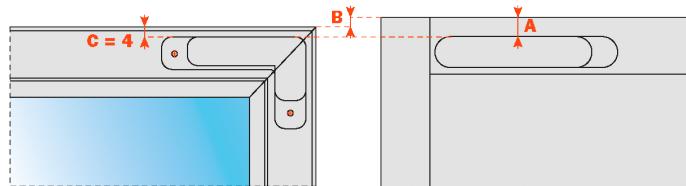

$$A = B + 4$$

$$B = A - 4$$

FLOS

F0031009 White

2620

Designed by Ron Gilad, 2013



170W - N/Dlm - 3000K - CRI > 90

Hanging lamp with indirect light. Stem and rings are in aluminium. The diffuser is in double satinized methacrylate. The power cable and the steel cable are 4 metres long. The power supply can be dimmed. The ceiling rose is covered with a mirrored disc.

Are you a professional and your project needs consulting and support?

[BOOK AN APPOINTMENT](#)

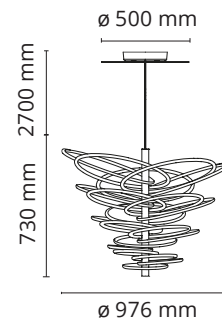

Main specifications

EAN	8059607013052
Mounting	Suspension
Environment	Indoor dry location
Light source type	LED
LED type	LED Module
Lamp holder	LED Module
Power (W)	170
System flux (lm)	N/D

Physical

Colour	White
Cord length (mm)	4000
Net weight (kg)	18.4
Package height (cm)	64
Package width (cm)	80
Package length (cm)	120
Package volume (m3)	0.61
IP	20
IP external	20

Download

[Mounting instructions](#) [↓ PDF](#)

[Mounting instructions](#) [↓ PDF](#)

Photometric Files

[LDT / IES](#) [↓ ZIP](#)

Technical Drawings

[2D](#) [↓ ZIP](#)



Photometric

Lighting type	Indirect
Light distribution	Asymmetric
CCT (K)	3000
CRI>	90

Electrical

Insulation class	I
Frequency (Hz)	50/60
Main voltage (Vac)	120-277
Driver	Integrated
Dimming type	Dimmable
Cord length (mm)	4000
Batteries inside	No
Charging min time	No

Ecodesign and Energy Labelling

This product contains a light source of energy efficiency class G

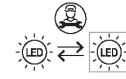

Replaceable (LED only) light source by a professional

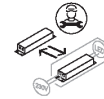

Replaceable control gear by a professional

KAP

DESIGNED BY FLOS ARCHITECTURAL

KAP Ø50
FIXED



KAP Ø50
ADJUSTABLE



LIGHT SOURCE
LED ARRAY
7,5W
595 lm
2700K/CRI 90
635 lm
3000K/CRI 90

KAP 80/
KAP 80 PLUS
FIXED



LIGHT SOURCE
LED ARRAY
max 13W
1370 lm
2700K/CRI 90
1460 lm
3000K/CRI 90

LIGHT SOURCE
LED ARRAY
13W
1800K-2850K
CRI 95
Dim To Warm*
*Only for KAP 80

KAP 80/
KAP 80 PLUS
WALL-WASHER



LIGHT SOURCE
LED
QR-CBC 51
GX5.3

LIGHT SOURCE
LED
PAR 16
GZ10

KAP 80/
KAP 80 PLUS
ADJUSTABLE



LIGHT SOURCE
LED ARRAY
max 13W
1370 lm
2700K/CRI 90
1460 lm
3000K/CRI 90

LIGHT SOURCE
LED ARRAY
13W
1800K-2850K
CRI 95
Dim To Warm*
*Only for KAP 80

LIGHT SOURCE
LED
QR-CBC 51
GX5.3

LIGHT SOURCE
LED
PAR 16
GZ10

KAP Ø105
FIXED



LIGHT SOURCE
LED ARRAY
23W
2690 lm
2700K/CRI 90
2870 lm
3000K/CRI 90

KAP Ø105
WALL-WASHER



LIGHT SOURCE
LED
QR-CBC 51
GX5.3

LED
PAR 16
GZ10

KAP Ø105
ADJUSTABLE



LIGHT SOURCE
LED
QR-CBC 51
GX5.3

KAP Ø105
DEEP



LIGHT SOURCE
LED ARRAY
23W
2690 lm
2700K/CRI 90
2870 lm
3000K/CRI 90

KAP 105
SQUARE
FIXED



LIGHT SOURCE
PHOSPHOR
LED
17W
1400 lm
2700K/CRI 98
3000K/CRI 98

LIGHT SOURCE
LED ARRAY
17W
1800 lm
2700K/CRI 90
2000 lm
3000K/CRI 90

LIGHT SOURCE
LED
QR-CBC 51
GX5.3

LED
PAR 16
GZ10

KAP Ø145
FIXED



LIGHT SOURCE
PHOSPHOR
LED
17W
1400 lm
2700K/CRI 98
3000K/CRI 98

KAP Ø145
WALL-WASHER



LIGHT SOURCE
LED ARRAY
17W
1800 lm
2700K/CRI 90
2000 lm
3000K/CRI 90

KAP Ø145
DEEP



K A P

Kap Ø80/Kap Ø80 Plus - Fixed - Optic Spot

Light Source: **Kap Ø80:** LED Array DC 500 mA - 9.2W - 935 lm - 2700K/CRI 90 / 9.2W - 974 lm - 3000K/CRI 90
Kap Ø80 Plus: LED Array DC 700 mA - 13W - 1370 lm - 2700K/CRI 90 / 13W - 1460 lm - 3000K/CRI 90

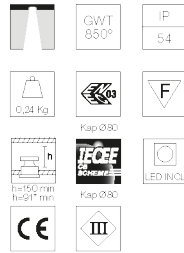
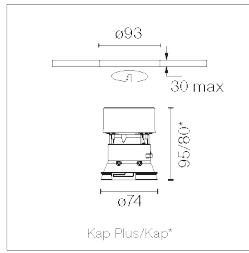

Incasso a LED. Fonte di alimentazione esclusa.
 Lente diffusore incluso.
 Cornice di pre-installazione da ordinare separatamente.

Recessed luminaire with LED light source. Power supply not included.
 Diffusing lens included.
 Pre-installation frame. To be ordered separately.

Alimentazioni raccomandate / Recommended power supply*:

	Kap Ø80	Kap Ø80 Plus
Non Dimmable	RF31855	60.9592
Dimmable 0/1-10V	RF27961	RF27961
Dimmable Dali 2	60.9222	60.9222
Mains Dimming	60.9411	60.9467
Casambi	60.9207	60.9207

* Vedi capitolo Drivers / Refer to the Drivers chapter

2700K

- Kap Ø80
- 03.4531.B1
- Kap Ø80 Plus
- 05.7451.B1

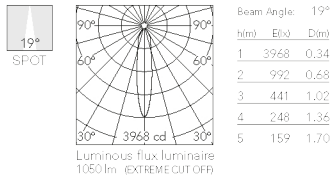

3000K

- Kap Ø80
- 03.4530.B1
- Kap Ø80 Plus
- 05.7450.B1

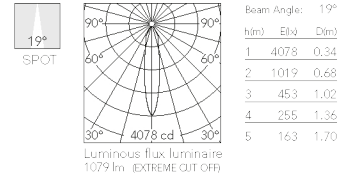

- Kap Ø80
- 03.4531.GL
- Kap Ø80 Plus
- 05.7451.GL

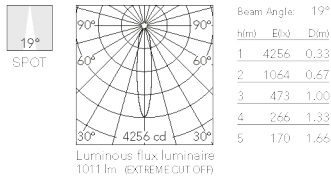

- Kap Ø80
- 03.4530.GL
- Kap Ø80 Plus
- 05.7450.GL

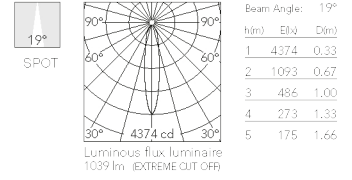

- Kap Ø80
- 03.4531.BU
- Kap Ø80 Plus
- 05.7451.BU

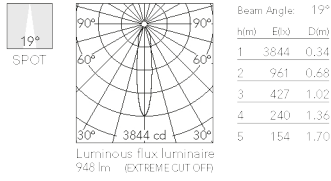

- Kap Ø80
- 03.4530.BU
- Kap Ø80 Plus
- 05.7450.BU

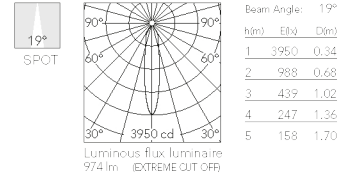

- Kap Ø80
- 03.4531.74
- Kap Ø80 Plus
- 05.7451.74

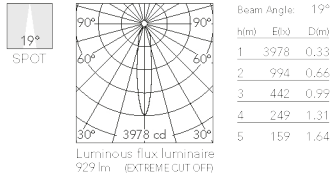

- Kap Ø80
- 03.4530.74
- Kap Ø80 Plus
- 05.7450.74

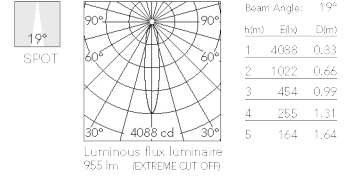

- Kap Ø80
- 03.4531.CU
- Kap Ø80 Plus
- 05.7451.CU

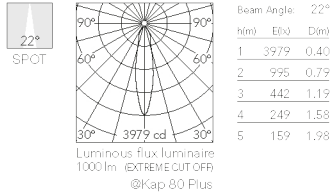

- Kap Ø80
- 03.4530.CU
- Kap Ø80 Plus
- 05.7450.CU

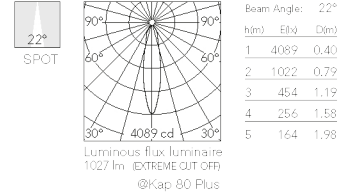

FLOS

F0001044 Gold

Skygarden 1

Designed by Marcel Wanders studio, 2007



Halogen - 105W

Suspension luminaire providing diffused lighting. Hemispherical, mechanically-processed cast plaster diffuser, painted white inside. Outer finish: rust, glossy black, glossy white or matte gold. Plaster diffuser support in die-cast aluminum alloy, liquid-painted white. Molded upper bushing in die-cast, polished aluminum alloy, protected with transparent paint on the entire visible part. Upper cable gland and blocking ring nut in black injection-molded PC (polycarbonate). Shaped, galvanized adjustment screws. Transparent, injection-molded, upper and lower silicone shock absorbers. Lamp holder and fixing support in black injection-molded PPS (polyphenylene sulfide). Flashed and blown opal glass diffuser. Molded fixing ring nut in die-cast aluminum alloy with alodine plating. Skygarden 1 frieze in photo-etched and mechanically drawn AISI 304 steel. Molded and galvanized steel ceiling attachment Gray, injection-molded PA6 (Nylon) rose.

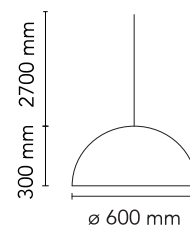

Are you a professional and your project needs consulting and support?

[BOOK AN APPOINTMENT](#)

Main specifications

EAN	8059607012772
Mounting	Suspension
Environment	Indoor dry location
Light source type	Bulb
Lamp category	Halogen
Lamp holder	E27
Ilcos	HSGS
Number of heads	1
Power (W)	105

Physical

Colour	Gold
Cord length (mm)	2700
Net weight (kg)	13
Package height (cm)	44
Package width (cm)	73
Package length (cm)	73
Package volume (m3)	0.23
IP	20
IP external	20

Download

[Mounting instructions](#) PDF

[Spare Parts](#) PDF

Photometric Files

[LDT / IES](#) LDT

Technical Drawings

[2D](#) ZIP

[3D](#) ZIP

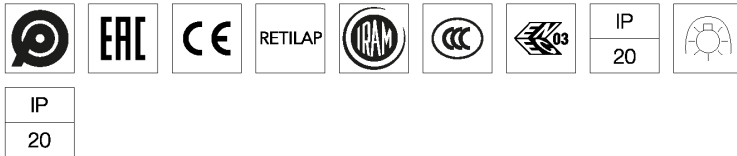

Schematic light drawing

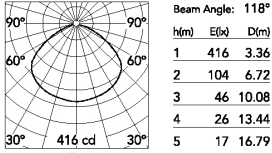

The above drawing is for illustrative purposes only and refers to product code: F64100XXWSKYGARDEN-1_150W-HL

Photometric

Lighting type	Direct
Light distribution	Symmetric

Electrical

Insulation class	I
Frequency (Hz)	50/60
Main voltage (Vac)	220-250
Cord length (mm)	2700
Batteries inside	No
Charging min time	No

Bulbs



NOT INCLUDED

RF29388

LED T46 Lamp E27 20W 2700K

Dimmable

Spare Parts



RF05382

Kit of 5 or rings



RF6410100

Skygarden 1 glass diffuser



RF6410144

Gold ceiling rose assembly

HECTOR — VINCENT VAN DUYSSEN 2020

1—
9



Modular, modern and flexible, the Hector system is designed to create aerial and dynamic compositions with elements exploiting the characteristics of mounting brackets secured between floor and ceiling or to the wall. The many combinations of possible finishes offer compositions that differ in terms of visual impact and attractive shapes, transforming Hector from a modern Hi-Tech bookcase into a traditional bookcase.

DATASHEET

REGISTERED
DESIGN

IX.2022

moltenigroup.com

Dimensions in centimeters and inches. The right to discontinue and make changes is reserved. This information is based on the latest product information available at the time of printing.

FINISHES

finishes

slate bronze/ pewter colour/ iris matt lacquered black oak sunrise oak extra-clear transparent glass smoked glass bonded hide leather

Frame

slate
bronze
pewter colour
iris

Matt lacquer insert

→ black
→ bronze
→ pewter colour
→ iris

components

	slate	bronze/ pewter colour/ iris	matt lacquered	black oak	sunrise oak	extra-clear transparent glass	smoked glass	bonded hide leather
ceiling/wall mounting bracket				*	**			
shelves	frame			*				
	insert		▲					
containers				*	**			
inner insert lower flap door								

Bonded hide leather

ivory
dark brown
natural
mud green
dove grey
black

- * The feet of the mounting brackets and the connections of the shelves and containers in black oak are always in a slate finish.
- ** The feet of the mounting brackets and the connections of the containers in sunrise oak are always in the same finish as the shelf frames with which they are combined in the composition.
- ▲ Inserts are always made to match the frame:

Molteni & C

2 –
9

TECHNICAL INFORMATION

MOUNTING BRACKET

Extruded aluminium, painted or anodised and clad in wood veneer.

SHELF FRAME

- Painted aluminium, composed of die-cast and extruded parts.
- Solid wood.

SHELF INSERTS

- Extra-clear transparent or smoked tempered glass.
- Medium-density fibreboard panel covered in wood veneer or with melamine and painted in the colours of the range.

CONTAINER WITH FLAP DOOR

Chipboard panel clad in wood veneer.

The inside of the flap door is available with a bonded hide leather insert in the colours of the range.

DECODER CONTAINER UNIT

Chipboard panel clad in wood veneer.

TV SUPPORT

Support in phenolic plywood with metal parts for mounting on the uprights.

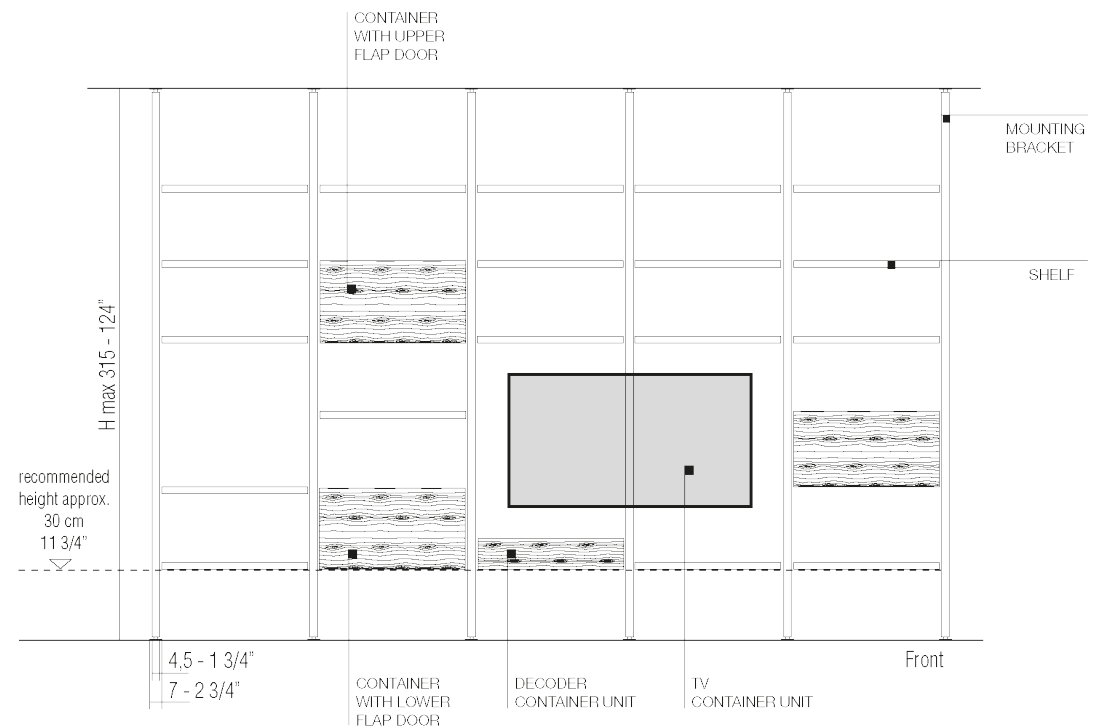

DATASHEET

REGISTERED
DESIGN
IX.2022

moltenigroup.com

Dimensions in centimeters and inches. The right to discontinue and make changes is reserved. This information is based on the latest product information available at the time of printing.

NOTES

- ▶ The mounting bracket, H max 315, can be made to measure, at no extra cost.
- ▶ The depth of the bookcase cannot be reduced.
- ▶ The shelf with a solid black oak frame is not available with LED lighting, or in W 113,1 cm.
- ▶ The shelf with a solid black oak frame and containers cannot be reduced in any way.
- ▶ Shelves with frames in slate, brown, pewter colour, bronze and iris can be reduced in width at a supplementary cost each.
Minimum reduced shelf measurement 30 cm (centre distance).

- ▶ The height positioning of the shelves and containers is at the customer's discretion.
- ▶ The positioning of the mounting brackets cannot be changed.
- ▶ The system involves anchoring the mounting brackets to the floor and ceiling.
- ▶ The unit with lower flap door is available with the door interior in bonded hide leather in Molteni range colours.
The flap door cannot be considered a worktop, but only a surface on which to place lightweight materials.
- ▶ The storage units only come with W 83,1 cm.

Compositional
ceiling fixing diagram

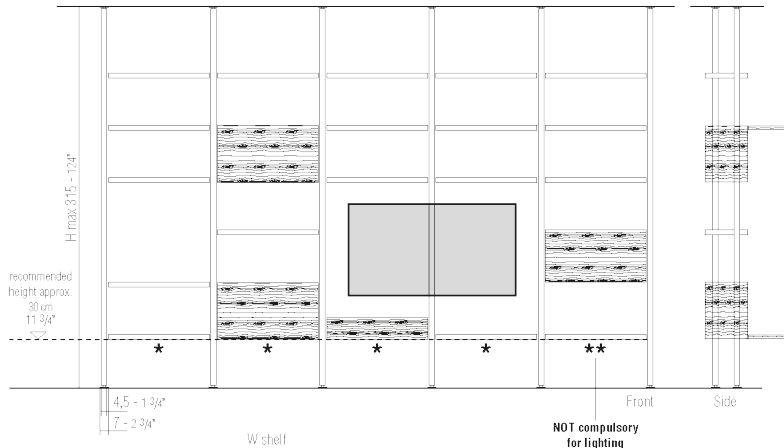

- * Compositions with lighting are required to have each module approximately 30 cm above the ground:
 - One shelf with aluminium frame and wood insert (wood or lacquered).
 - Or a decoder unit, a drawer unit or a unit with lower flap door.
 All these elements must be aligned as they are required for the electrical connection.

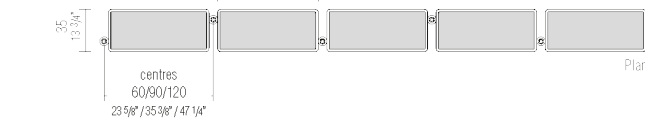

Mounting bracket positioning

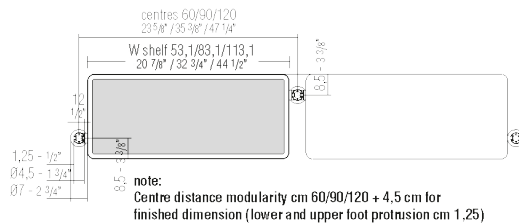
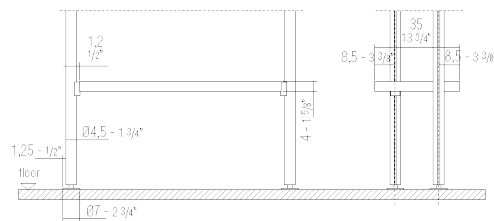
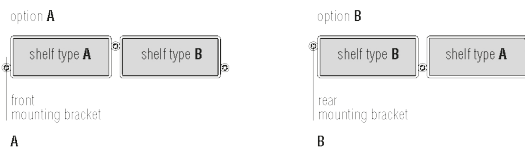

note:
For the construction of the ceiling mounting brackets it is necessary and sufficient to communicate the height of the room. In the case of unaligned dimensions, check the tolerances indicated below.

Ceiling fixing tolerances

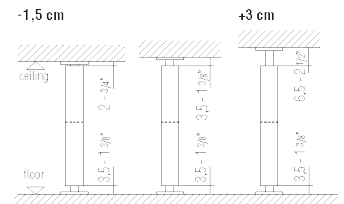

Shelf capacity with aluminium frame:

- W 53,1 = Kg. 15
- W 83,1 = Kg. 23
- W 113,1 = Kg. 27

Shelf capacity with solid wood frame:

- W 53,1 = Kg. 9
- W 83,1 = Kg. 15

Flap door capacity = kg. 4

Container interior capacity = kg. 8

Unit surface capacity = Kg. 15

NOTES

- ▶ The mounting bracket, H max 315, can be made to measure, at no extra cost.
- ▶ The depth of the bookcase cannot be reduced.
- ▶ The shelf with a solid black oak frame is not available with LED lighting, or in W 113,1 cm.
- ▶ The shelf with a solid black oak frame and containers cannot be reduced in any way.
- ▶ Shelves with frames in slate, brown, pewter colour, bronze and iris can be reduced in width at a supplementary cost each.
Minimum reduced shelf measurement 30 cm (centre distance).

- ▶ The height positioning of the shelves and containers is at the customer's discretion.
- ▶ The positioning of the mounting brackets cannot be changed.
- ▶ The system involves anchoring the mounting brackets to the wall and at the floor.
- ▶ The unit with lower flap door is available with the door interior in bonded hide leather in Molteni range colours.
The flap door cannot be considered a worktop, but only a surface on which to place lightweight materials.
- ▶ The storage units only come with W 83,1 cm.

Compositional
wall fixing diagram

Molteni & C

4
C

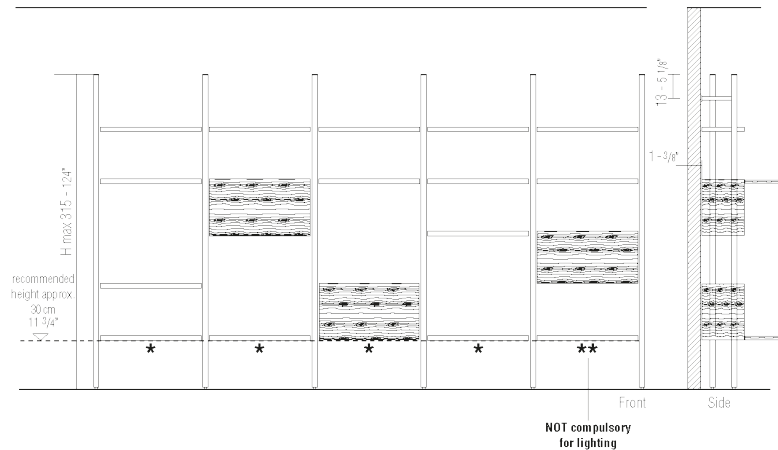

- ★ Compositions with lighting are required to have each module approximately 30 cm above the ground:
 - One shelf with aluminium frame and wood insert (wood or lacquered).
 - Or a decoder unit, a drawer unit or a unit with lower flap door.
 All these elements must be aligned as they are required for the electrical connection.

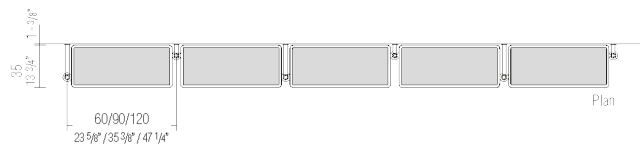

Mounting bracket positioning

option A

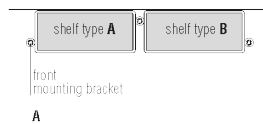

option B

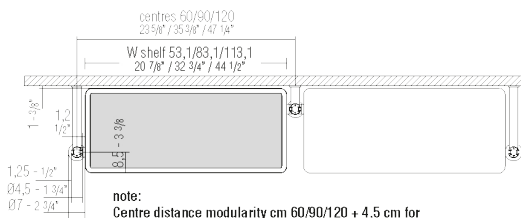
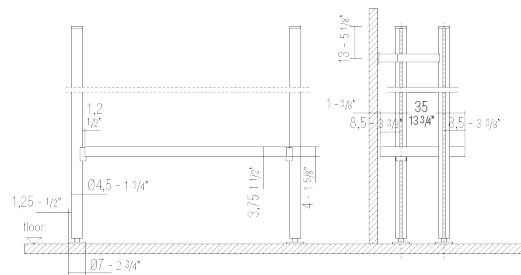
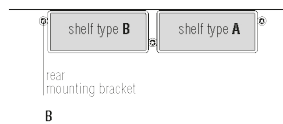

Shelf capacity with aluminium frame:
W 53,1 = Kg. 15
W 83,1 = Kg. 23
W 113,1 = Kg. 27

Shelf capacity with solid wood frame:
W 53,1 = Kg. 9
W 83,1 = Kg. 15

Flap door capacity = kg. 4
Container interior capacity = kg. 8
Unit surface capacity = Kg. 15

DATASHEET

REGISTERED
DESIGN

IX.2022

moltenigroup.com

Dimensions in centimeters and inches. The right to discontinue and make changes is reserved. This information is based on the latest product information available at the time of printing.

LED LIGHTING

- The shelves can be fitted with LED lighting.
- The system complies with European safety regulations.
- To light the walk-in closet, the mounting brackets are wired with an electrified cable duct and the shelves fitted with a power socket.
- For each module of the composition, it is possible to insert 1 or more shelves with LED lighting and, through the electrified cable duct inserted in the mounting brackets, the shelf can be moved at will.
- Each power supply unit supports LEDs up to 72 watt. To calculate the number of power supply units required, see the example on page 6.
- The electrical system starts from the sx-left mounting bracket of the first module to be electrified.

► Compositions with lighting are required to have each module approximately **30 cm above the ground**:

- One shelf with aluminium frame and wood insert (wood or lacquered).
 - Or a decoder unit, a drawer unit or a unit with lower flap door.
- All these elements must be aligned as they are required for the electrical connection.

Molteni & C

Exploded-view drawing

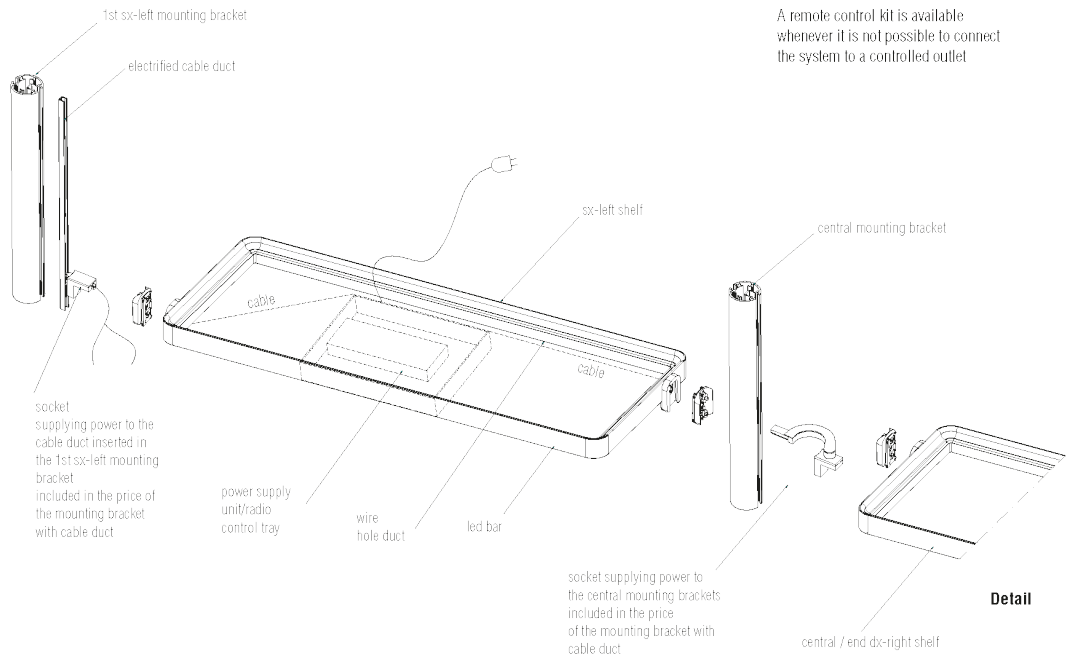

5 —
9

Examples

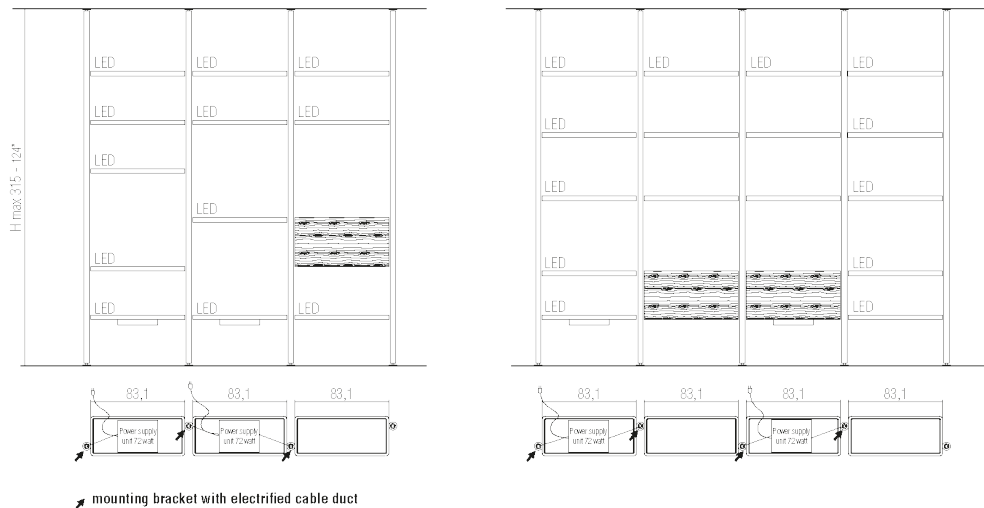

DATASHEET

REGISTERED
DESIGN

IX.2022

moltenigroup.com

Dimensions in centimeters and inches. The right to discontinue and make changes is reserved. This information is based on the latest product information available at the time of printing.

LED LIGHTING

Notes

When ordering, indicate the shelves with LED lighting.

Molteni & C

6

9

Example calculation for power supply unit

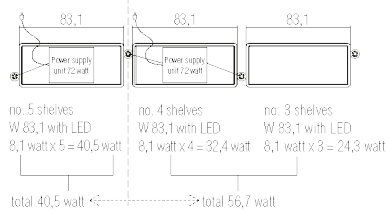
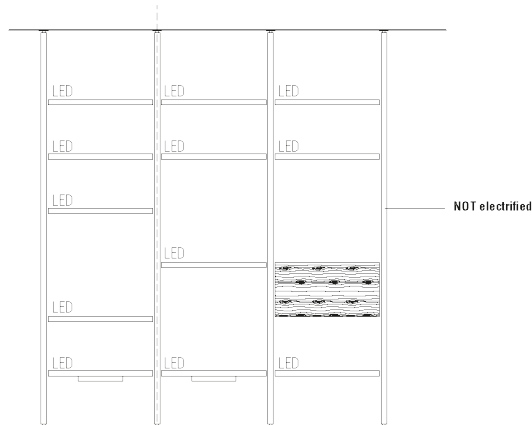

Lighting system consisting of:

- no. 3 mounting brackets with electrified cable duct
- no. 1 mounting bracket without electrified cable duct
- no. 12 shelves with LED lighting
- no. 2 power supply units 72 watt

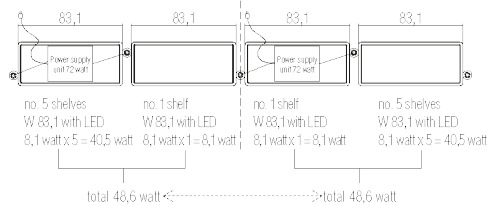
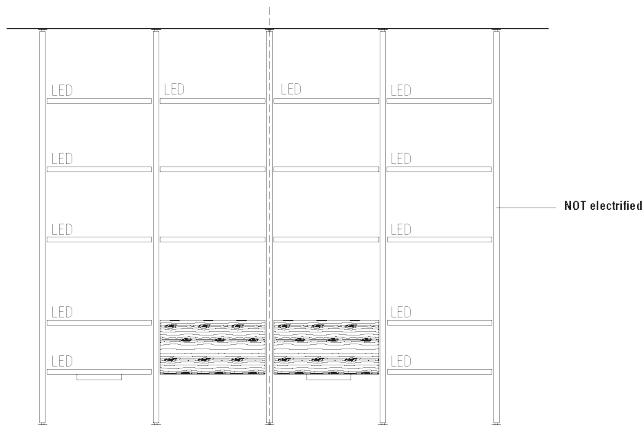

Lighting system consisting of:

- no. 4 mounting brackets with electrified cable duct
- no. 1 mounting bracket without electrified cable duct
- no. 12 shelves with LED lighting
- no. 2 power supply units 72 watt

DATASHEET

REGISTERED
DESIGN

IX.2022

moltenigroup.com

Dimensions in centimeters and inches. The right to discontinue and make changes is reserved. This information is based on the latest product information available at the time of printing.

DIMENSIONS

- ▶ The mounting bracket, H max 315, can be made to measure, at no extra cost.
- ▶ Shelves with frames in slate, pewter colour, bronze and iris can be reduced in width at a supplementary cost each (with or without LED lighting). Minimum reduced shelf measurement 30 cm (centre distance of mounting brackets).
- ▶ The mounting brackets are prepared for ceiling, floor, and wall fixing.
The dealer is tasked with choosing the most suitable and safest fixing means for each specific situation.
We recommend a scrupulous preliminary check of the structural state of the ceilings or walls before ordering and installing the Hector unit.

Mounting brackets

H max 315 - 124"
Ø 4,5 - 1 3/4"

Ceiling



without electrified
cable duct
PFS031

with electrified
cable duct
PFS031K

Wall version A

beam 25 - 0.78"

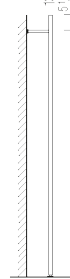

without electrified
cable duct
PFPA31

with electrified
cable duct
PFPA31K

Wall version B

beam 7 - 2 3/4"

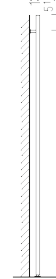

without electrified
cable duct
PFPB31

with electrified
cable duct
PFPB31K

Molteni & C

7—
9

Shelves frame slate

D 35 th 4
D 13 3/4" th 1 5/8"

W 60 - 23 5/8"
4.7 wall



type A
REA3/06

type B
REB3/06

W 90 - 35 3/8"
8.1 wall



type A
REA3/09

type B
REB3/09

W 120 - 47 1/4"
11.4 wall



type A
REA3/12

type B
REB3/12

Shelves frame pewter colour/bronze/iris

D 35 th 4
D 13 3/4" th 1 5/8"

W 60 - 23 5/8"
4.7 wall



type A
RIA3/06

type B
RIB3/06

W 90 - 35 3/8"
8.1 wall



type A
RIA3/09

type B
RIB3/09

W 120 - 47 1/4"
11.4 wall

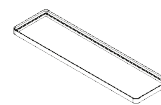

type A
RIA3/12

type B
RIB3/12

DATASHEET

REGISTERED
DESIGN

IX.2022

moltenigroup.com

Dimensions in centimeters and inches. The right to discontinue and make changes is reserved. This information is based on the latest product information available at the time of printing.

DIMENSIONS

- ▶ The shell with a solid black oak frame is not available with LED lighting.
- ▶ The shell with a solid black oak frame and containers cannot be reduced in any way.
- ▶ The flap door interior of the unit CARA03/09 - CARB03/09 is available with a bonded hide leather insert.

Molteni & C

8

9

Shelves frame solid black oak

W 60 - 23 5/8"

W 90 - 35 3/8"

D 35 th 4
D 13 3/4" th 1 5/8"



type A
RMA3/06

type B
RMB3/06

type A
RMA3/09

type B
RMB3/09

Container with lower flap door

W 90 - 35 3/8"

Optional internal shelf

D 35 H 46
D 13 3/4" H 18 1/8"

W 77 D 25,5 th 2,2
W 30 3/8" D 10" th 7/8"

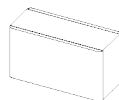

type A
CARA3/09

type B
CARB3/09

CR13/09

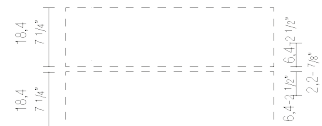

Drawer unit

W 90 - 35 3/8"

D 35 H 17,8
D 13 3/4" H 7"



type A
CCAA3/09

type B
CCAB3/09

Container with upper flap door

W 90 - 35 3/8"

Optional internal shelf

D 35 H 46
D 13 3/4" H 18 1/8"

W 77 D 25,5 th 2,2
W 30 3/8" D 10" th 7/8"

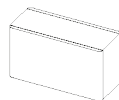

type A
CASA3/09

type B
CASB3/09

CR13/09

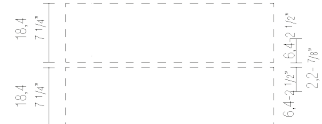

DATASHEET

REGISTERED
DESIGN

IX.2022

moltenigroup.com

Dimensions in centimeters and inches. The right to discontinue and make changes is reserved. This information is based on the latest product information available at the time of printing.

DIMENSIONS

TV signal transceiver system for decoder container unit
The Ø 1,8 sensor can be positioned as desired.

**Decoder container unit
with lower flap door**

D 35 H 17,8
D 13 3/4" H 7"

Only usable for
wall compositions

W 90 - 35 3/8"



type A
CPDA3/09 type B
CPDB3/09

**TV signal transceiver system
with LED light for decoder container
(transmission frequency from 30 to 38 KHz)**

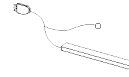

for 1 compartment
ETV1L

**TV support
module**

D 9 H 50
D 3 1/2" H 19 5/8"

STANDARD VESA connection for TVs
with screen sizes from 40" to 65".
Mounting on free in height
mounting bracket
(rear mounting bracket
recommended)

Included in the price mtl 0.50 profile
for cable routing (see detail)

W 50
W 19 5/8"

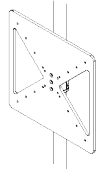

EMPT1

Examples of use

TV support module
Example 60 modules
Recommended TVs: 40" - 43"

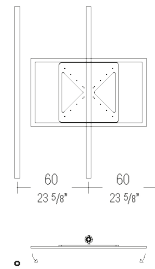

TV support module
Example 90 modules
TV screen types recommended : 49" - 65"

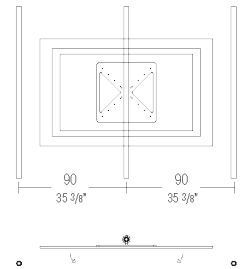

**Cable passage behind
the mounting bracket**

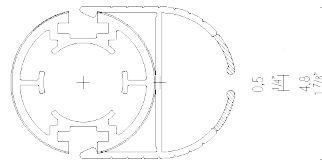

**System
components**

**power supply unit 72 watt
with tray**
(positioned under the first left
lower shell)

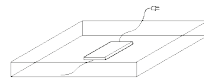

EAL72

**remote control kit
with dimmer**
(no. 1 for power supply unit)



EKRR3

DATASHEET

REGISTERED
DESIGN

IX.2022

moltenigroup.com

Dimensions in centimeters and inches. The right to discontinue and make changes is reserved. This information is based on the latest product information available at the time of printing.

Teatro — design Marc Berthier, 1979/2010



“Historically, travelling theatres such as the Commedia dell’Arte or that of Moliere’s company performed in public squares, on a “stage” made of floorboards set on trestles, known in Italy as Piccolo Teatro, or small theatre.

Thus, Teatro trestle is the archetype for the adjustable trestles used with drawing boards by artists, architects, etc.

Marc Berthier redesigned it for Magis in 1979, seeking in its proportions a structural and functional harmony such that it could be

used for a work table (in both a seated and a standing position), dinner table or console table.

It is made of solid beech wood, and assembled using visible tenons and mortices. The table was re-issued by Magis in 2010.”

Marc Berthier



Designer in Magis



Teatro — design Marc Berthier, 1979/2010
Technical Sheet

Pair of trestles adjustable in height

i
Material: solid beech. Tops in tempered glass or in MDF laminate (one side black, the other white) with edge in natural beech. Magis logo is stamped on each product of our collection vouching for their originality.

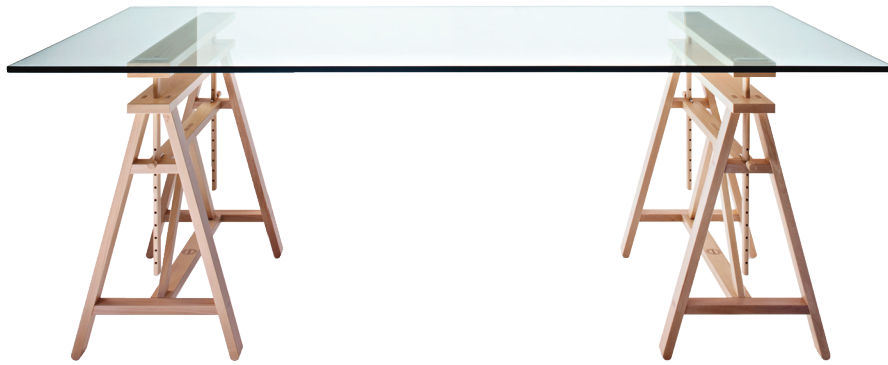
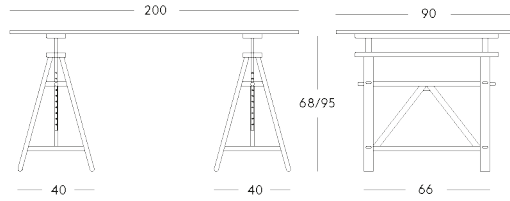

Frame: Natural Beech
Top: Transparent glass



Frame: Natural Beech
Top: White MDF 8500 / Black
MDF 8510 (reversible)



Designer



Marc Berthier

Designer and architect Marc Berthier was one of the first designers to collaborate with Magis, designing numerous objects and collections for the company.

His work mainly revolves around industrial product design, and is spiced with international flavours: some of his creations have been selected for the permanent collections of the Musée National d'Art Moderne, the Arts-Décoratifs Museum and the Fond National d'Art Contemporain in France, and the MoMA in New York.

In 2002 he founded Eliumstudio in Paris, together with his daughter Élise, Pierre Garner and Frédéric Lintz, joined later by Anne Klepper.



arper

Kinesit Task - Trestle swivel #4853



Selected Options
Base Finish: LU1 Shiny Aluminum
Shell Color: White
Program: Carded In
Fabric Type: HA Hallingdal Kvadrat
Fabric Grade: G
Fabric Color: HA00100
Armrests: Yes
Armrest Type: Armrest

Certifications

Technical Specifications

Resistance Test

Fire Retardant Test

FLOS

F6630057 Chrome

Superloon

Designed by Jasper Morrison, 2015

48W - 2716lm - 2200-2800K



Adjustable floor lamp providing direct light. Painted or chrome-plated aluminium body with metal spinning head, die-cast joints and extruded stem. Silk screened PMMA diffuser. Edge Lighting technology light source. Optical switch sensor placed on the stem that provide Warm Tone dimming function. Power cord length 250 cm. Plug-in power supply with interchangeable plugs.

Are you a professional and your project needs consulting and support?

[BOOK AN APPOINTMENT](#)

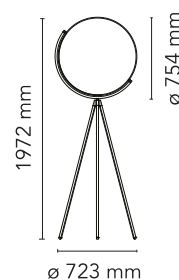

Main specifications

EAN	8059607007037
Mounting	Floor
Environment	Indoor dry location
Light source type	LED
LED type	LED Module
Lamp holder	LED Module
Number of heads	1
Power (W)	48
System flux (lm)	2716

Physical

Colour	Chrome
Net weight (kg)	11
Package volume (m3)	0.11
IP	20
IP external	20

Download

- [Mounting instructions](#) PDF
- [Mounting instructions](#) PDF
- [Spare Parts](#) PDF

Photometric Files

- [LDT / IES](#) LDT

Technical Drawings

- [2D](#) ZIP
- [3D](#) ZIP



Schematic light drawing

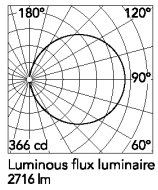

Photometric

Lighting type	Direct
Light distribution	Roto symmetric
CCT (K)	2200-2800

Electrical

Insulation class	III
Frequency (Hz)	50/60
Main voltage (Vac)	100-240/48
Driver	Remote included
Dimming type	Electronic 12V
Plug type	Type G, Type A, Type C
Batteries inside	No
Charging min time	No

Ecodesign and Energy Labelling

This product contains a light source of energy efficiency class D

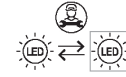

Replaceable (LED only) light source by a professional

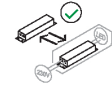

Replaceable control gear by an end-user

Spare Parts



F6632057

Chrome diffuser



RF25119

Mobile legs



RF3320400

Black plug assembly kit & 48V driver



RF6630157

Chrome electrified fixed leg



Mensch,
Handarbeit, Zement
50 104
h ca. 160 cm

Mensch,
Handarbeit, Zement
50 105
h ca. 200 cm

Cozinha > Máquina de café > CLC 835 MC BK-SS



_MAESTRO > CLC 835 MC BK-SS

Máquina de café multicápsulas e café pré moído

REF. 40589513 EAN. 8421152145616

Selecione uma cor: Vidro preto com aro inox



- Válida para cápsulas e café moído
- Capacidade: 1 chávina
- Pressão: 19 bares
- Iluminação LED

COMPRAR

Cozinha > Micro-ondas > ML 8220 BIS



_MAESTRO > ML 8220 BIS

Edição Urban Colors Micro-ondas + Grill de integração total com base cerâmica 22 litros

REF. 112030001 EAN. 8434778007688

Selecione uma cor: Vidro preto



- Micro-ondas de base cerâmica + grill
- Painel de comandos eletrônico em vidro e relógio digital
- Grill rebatível, 1.200 W
- 5 níveis de potência, 850 W de saída de micro-ondas
- Interior em aço inoxidável
- 9 menus de acesso direto

COMPRAR

RSR 41150 BU EU



NOVO _TOTAL > RSR 41150 BU EU

Frigorífico de integração baixo bancada com congelador integrado

REF. 113470014 EAN. 8434778021875

★★★★★ (0) Escrever uma análise



- Termostato regulável
- 2 prateleiras de vidro
- Iluminação LED



[_MAESTRO](#) > CC 485

Chaminé decorativa ilha e motor ECOPOWER A em 40 cm

REF. 40480330 EAN. 8421152145869



Ficha de produto EU [↓](#)

Selecione uma cor: Inox



- Capacidade de extração máx. até 771 m³/h
- 3 velocidades + 1 intensiva
- Lâmpadas LED
- Motor Ecopower
- Funcionamento temporizado

COMPRAR

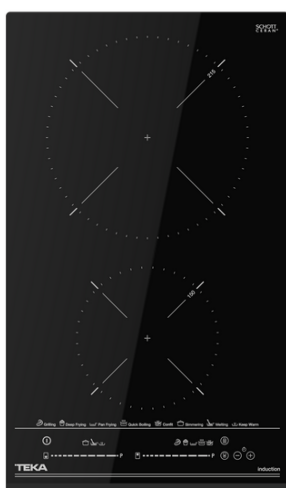

[_MAESTRO](#) > IZC 32600 MST

Placa modular de indução de 30 cm Multislíder e 2 zonas de cozinhado

REF. 112510022 EAN. 8434778012019

★★★★★ (0) [Escrever uma análise](#)

Selecione uma cor: Vidro preto



- Placa de indução modular
- Painel de comandos Touch Control MultiSlider
- 2 zonas de cozinhado
- Funções diretas de cozinhado
- Bloqueio de segurança para crianças

COMPRAR



Molteni & C

GLOVE — PATRICIA URQUIOLA 2005

1—
2



A technical structure with strategic padding is stretched by a light metal structure. Patricia Urquiola's idea brought about a whole line of seats, aerial elastic surfaces providing pure comfort. Leather or fabric: fluid shake and continuous profiles where the detail of a curve creates a silhouette without any additions or accessories. Impeccable display of minimalism.



**The Chicago Athenaeum
Good Design Award 2007: Glove**



This symbol shows that the product has removable upholstery. Only qualified personnel can remove the upholstery of some of our products. If this information is pertinent, it will be included in the warnings section.



This symbol shows that the product is available on request in a fire resistant version that complies with the standards BS 5852 and TB 117-2013.

The buyer is responsible for checking to make sure that the product is suitable and compliant with the requirements for the designated use and the current applicable laws and standards for the destination and use of the product.

DATASHEET

REGISTERED
DESIGN

IX.2021

FINISHES

NOTES

The closing zip located on the back of Glove chairs and armchairs is an essential detail to outline the silhouette of the object. The zip is available in two colours: black and white - Molteni&C decides the most suitable colour combination for the various fabric and leathers types and colours in the collection. Any requests for a specific combination (black or white zip) must be specified when ordering.

TECHNICAL INFORMATION

STRUCTURE (ALL VERSIONS)

Steel folded and welded with protective paint.

SEAT (CHAIR AND SMALL ARMCHAIR)

Frame of thermoplastic material with inserted element of polyurethane foam.

BACK (SMALL ARMCHAIR)

SMC (polyester resin compound reinforced with fibreglass) body with shaped insert in foam polyurethane.

FEET

Non-slip plastic.

REMOVABLE OUTER COVERS

(See attached card, specific for each cover).



AVAILABLE IN FIRE-RESISTANT
VERSION TB117 AND BS5852

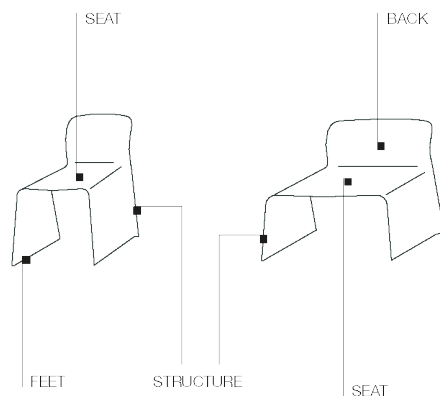

DIMENSIONS

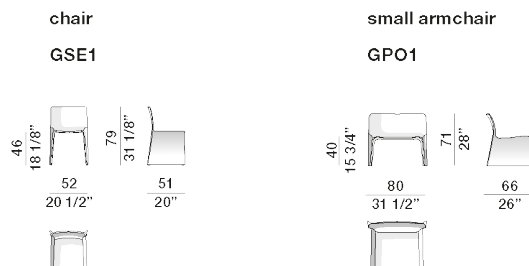

DATASHEET

REGISTERED
DESIGN

IX.2021

code	gross weight kg.	volume mc.	packages	code	gross weight kg.	volume mc.	packages
GP01	18	0,452	1	GSE1	8,5	0,184	1

The Visitor small

Designer Guido Deleu

Category Terra

In collection The Visitor

Description

The Visitor is a kind figure whom anyone would welcome with open arms. Smooth lines, a friendly appearance and an extensive colour palette make this art object an iconic Gardeco favourite since its launch in 2009.

The figurine is designed by the Belgian sculptor **Guido Deleu** and is available in ceramic, skilfully manufactured by hand at the studio Cores da Terra in Brazil, as well as in **bronze**, cast using the lost wax method, a technique that dates back from the third millennium B.C.

[CONTACT >](#)

The Visitor small cor 01 - white, cor 26 nuvem, cor 03 ochre clear , cor 22 - clay, cor 02 - sand

Pisco

Designer Stefan Schöning

Category Muralis

In collection Pisco

Description

Pisco is Portuguese for blink of an eye. It is a wall composition designed by the Belgian designer **Stefan Schöning** that consists of ceramic discs. Due to the bent surface of each disc, a shadow is cast on one half and light on the other, creating an interesting and mesmerising shadow effect.

Pisco is available in three sizes and in three shades of brown and one off-white shade. Each individual disc can be attached to the wall with magnets, allowing the user to create an entirely free composition.

It is an extraordinarily creative piece of design that is particularly fit for integration in custom made projects, entrance halls, receptions, hotel rooms etc.

OCTAVE — VINCENT VAN DUYSSEN 2020

1—
9



Octave is a system of modular sofas featuring rigorous shapes. A design marked by geometrical lines, based on mix & match modular elements that came together in linear, angular compositions or with the addition of hanging trapezoidal or rectangular elements in unusual and highly appealing configurations. Blade-like extruded steel legs support the base on which rest low rectangular fabric or leather upholstered backrests, of the same thickness as the cosy seat cushions. Guaranteeing the utmost comfort, complementary cushions, again rectangular or square, along with the headrest that can be freely positioned on the backrest, enabling it to be used in various positions. In addition to the traditional linear or corner elements, Octave offers open elements with which to create chaises longues or poufs that can be arranged alongside the composition or used as free-standing elements, also for the centre of the room. The conjoining rectangular or trapezoidal elements feature innovative hide leather trays on which to place all kinds of objects. Thanks to the possibility of creating articulated compositions, Octave is ideal in a “smart working” environment via the use of binding components designed to support laptops and tablets.



This symbol shows that the product has removable upholstery. Only qualified personnel can remove the upholstery of some of our products. If this information is pertinent, it will be included in the warnings section.



This symbol shows that the product is available on request in a fire resistant version that complies with the standards BS 5852 and TB 117-2013.

The buyer is responsible for checking to make sure that the product is suitable and compliant with the requirements for the designated use and the current applicable laws and standards for the destination and use of the product.

DATASHEET

REGISTERED
DESIGN

IX.2021

moltenigroup.com

Dimensions in centimeters and inches. The right to discontinue and make changes is reserved. This information is based on the latest product information available at the time of printing.

NOTES

- ▶ List codes with **final A:**
Depth 105 cm.
- ▶ List codes with **final C:**
Depth 95 cm.
- ▶ For correct ergonomics and maximum comfort, we recommend designing each module with a backrest cushion, headrest and lower back support cushion, in accordance with the pairings/measurements suggested in the price list. In addition to correct ergonomics, the presence of these elements makes the product look complete and elegant.
- ▶ **ATTENTION:**
The trinket trays cannot be ordered individually but only combined with the modules provided in the price list.
- ▶ The corner shelf must always be used with one padded element on the right and another on the left.
The corner shelf cannot be used as an end/final element.

Molteni&C

When ordering

Specify the measurements of backrests, headrests and back support cushions.

3

9

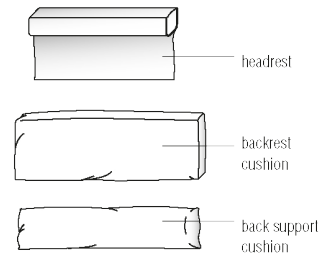
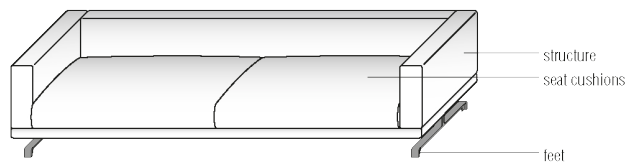

Corner shelf

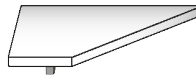

Trinket trays



DATASHEET

REGISTERED
DESIGN

IX.2021

moltenigroup.com

Dimensions in centimeters and inches. The right to discontinue and make changes is reserved. This information is based on the latest product information available at the time of printing.

DIMENSIONS

Octave depth 95

Molteni & C

4

9

sofa
DI270C

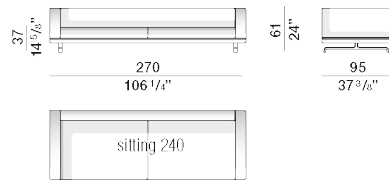

back cushion
W 120 - 47 1/4"



back cushion
W 105 - 41 3/8"

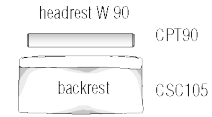

ornamental cushion
PCU90/75

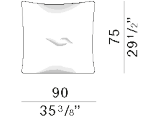

sofa
DI240C

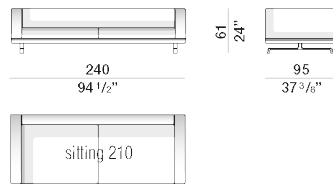

back cushion
W 105 - 41 3/8"



back cushion
W 90 - 35 3/8"

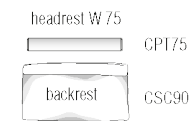

ornamental cushion
PCU90/75

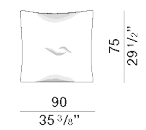

sofa
DI210C

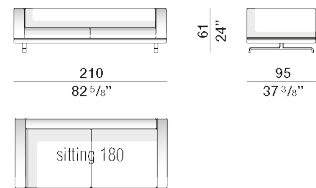

back cushion
W 90 - 35 3/8"

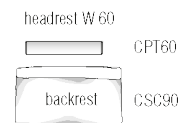

back cushion
W 75 - 29 1/2"

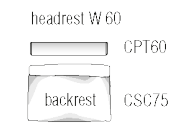

ornamental cushion
PCU90/75

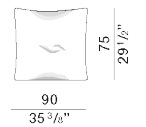

DATASHEET

REGISTERED
DESIGN

IX.2021

moltenigroup.com

Dimensions in centimeters and inches. The right to discontinue and make changes is reserved. This information is based on the latest product information available at the time of printing.

DIMENSIONS

Octave depth 105

Molteni & C

5

9

sofa
DI270A

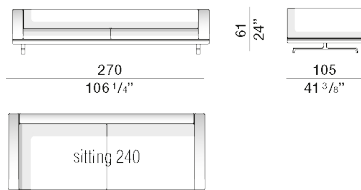

back cushion
W 120 - 47 1/4"

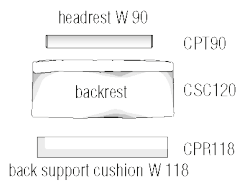

back cushion
W 105 - 41 3/8"

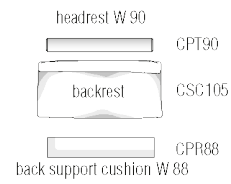

ornamental cushion
PCU90/75

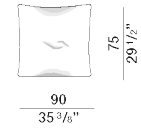

sofa
DI240A

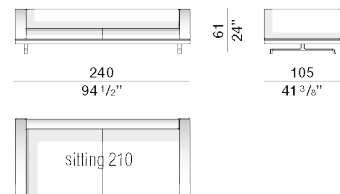

back cushion
W 105 - 41 3/8"

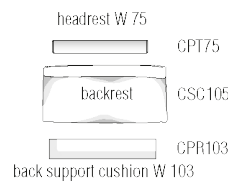

back cushion
W 90 - 35 3/8"

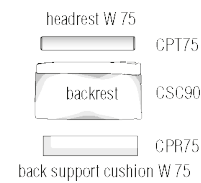

ornamental cushion
PCU90/75

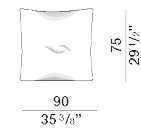

sofa
DI210A

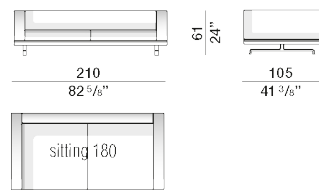

back cushion
W 90 - 35 3/8"

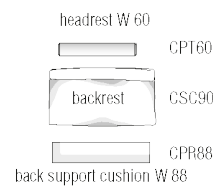

back cushion
W 75 - 29 1/2"

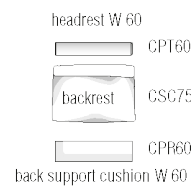

ornamental cushion
PCU90/75

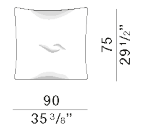

end element
TE255A dx - sx

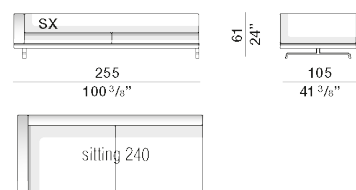

back cushion
W 120 - 47 1/4"

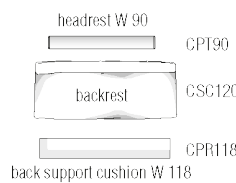

back cushion
W 105 - 41 3/8"

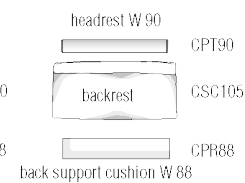

ornamental cushion
PCU90/75

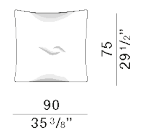

end element
TE225A dx - sx

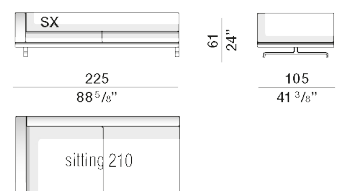

back cushion
W 105 - 41 3/8"

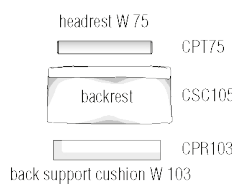

back cushion
W 90 - 35 3/8"

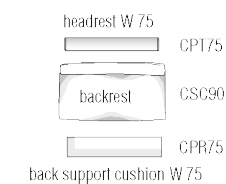

ornamental cushion
PCU90/75

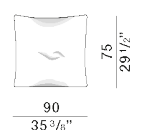

DATASHEET

REGISTERED
DESIGN

IX.2021

moltenigroup.com

Dimensions in centimeters and inches. The right to discontinue and make changes is reserved. This information is based on the latest product information available at the time of printing.

DIMENSIONS

Octave depth 105

Molteni&C

6

9

end element
TE195A dx - sx

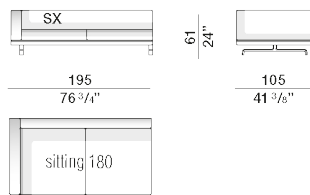

back cushion
W 90 - 35 3/8"

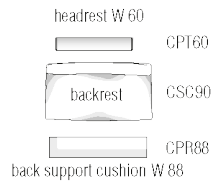

back cushion
W 75 - 29 1/2"

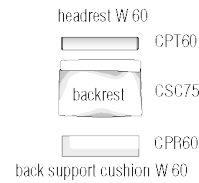

ornamental cushion
PCU90/75

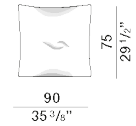

end element
TE135A dx - sx

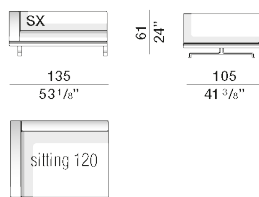

back cushion
W 120 - 47 1/4"

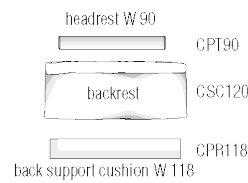

back cushion
W 105 - 41 3/8"

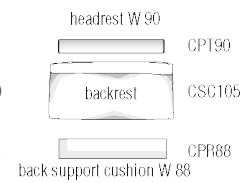

ornamental cushion
PCU90/75

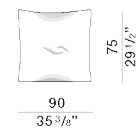

end element with tray (60x90)
TV255A dx - sx

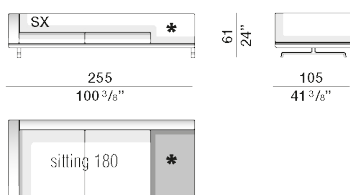

back cushion
W 90 - 35 3/8"

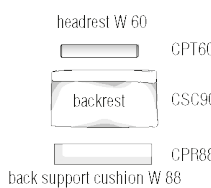

back cushion
W 75 - 29 1/2"

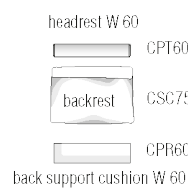

ornamental cushion
PCU90/75

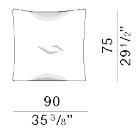

end element with tray (60x90)
TV195A dx - sx

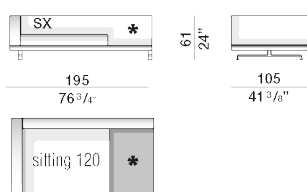

back cushion
W 120 - 47 1/4"

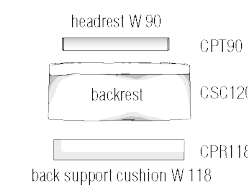

back cushion
W 105 - 41 3/8"

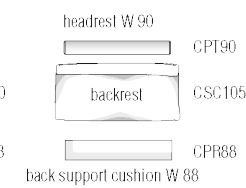

ornamental cushion
PCU90/75

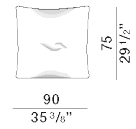

central element
CT210A

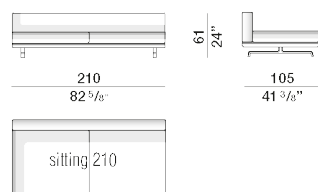

back cushion
W 105 - 41 3/8"

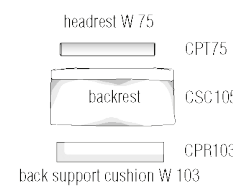

back cushion
W 90 - 35 3/8"

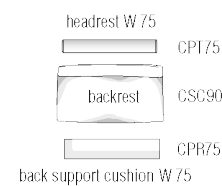

ornamental cushion
PCU90/75

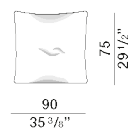

DATASHEET

REGISTERED
DESIGN

IX.2021

moltenigroup.com

Dimensions in centimeters and inches. The right to discontinue and make changes is reserved. This information is based on the latest product information available at the time of printing.

DIMENSIONS

Octave depth 105

Molteni&C

7

9

central element
CT180A

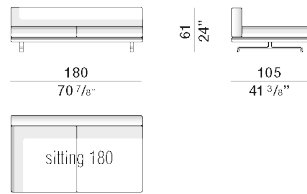

back cushion
W 90 - 35 3/8"

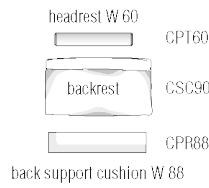

back cushion
W 75 - 29 1/2"

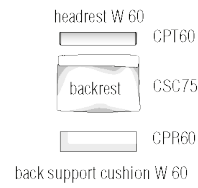

ornamental cushion
PCU90/75

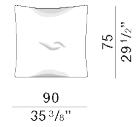

central element
CT120A

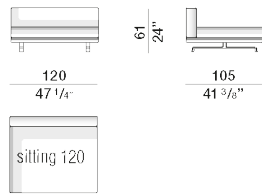

back cushion
W 120 - 47 1/4"

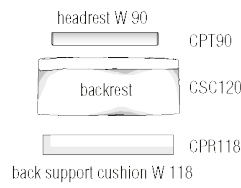

back cushion
W 105 - 41 3/8"

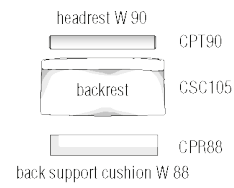

ornamental cushion
PCU90/75

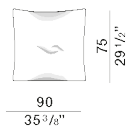

island element
IS150A dx - sx

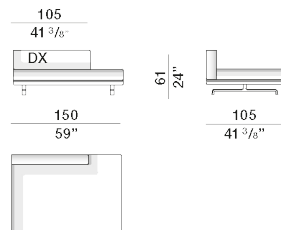

back cushion
W 105 - 41 3/8"

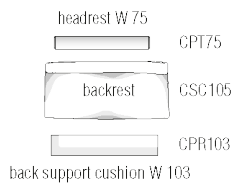

back cushion
W 90 - 35 3/8"

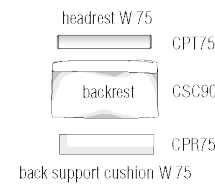

ornamental cushion
PCU90/75

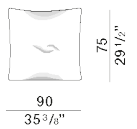

island element with tray (60x90)
IV240A dx - sx

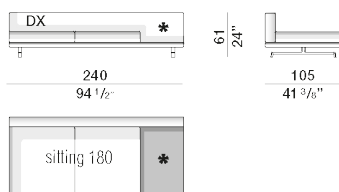

back cushion
W 90 - 35 3/8"

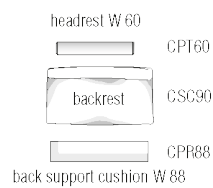

back cushion
W 75 - 29 1/2"

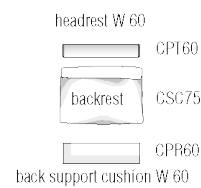

ornamental cushion
PCU90/75

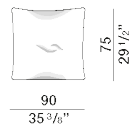

island element with tray (60x90)
IV180A dx - sx

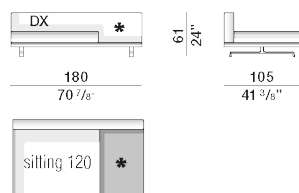

back cushion
W 120 - 47 1/4"

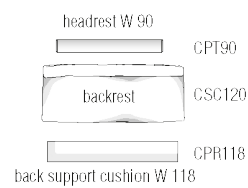

back cushion
W 105 - 41 3/8"

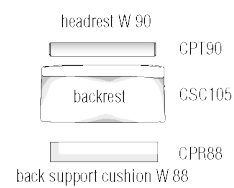

ornamental cushion
PCU90/75

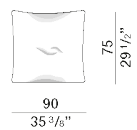

DATASHEET

REGISTERED
DESIGN

IX.2021

moltenigroup.com

Dimensions in centimeters and inches. The right to discontinue and make changes is reserved. This information is based on the latest product information available at the time of printing.

DIMENSIONS

island element with tray (60x90)

IV150A dx - sx

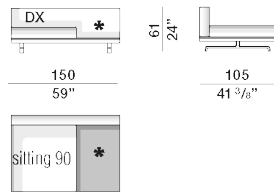

chaise longue

CL105 dx - sx

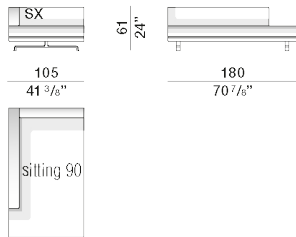

daybed

DB105

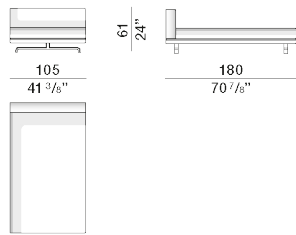

corner island element

IA224A dx - sx

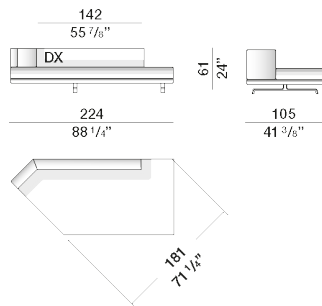

pouf

PF105A

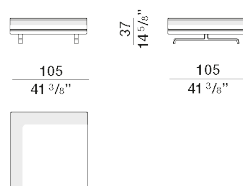

back cushion

W 90 - 35 3/8"

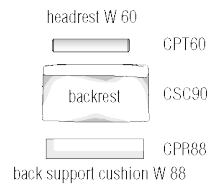

back cushion

W 90 - 35 3/8"

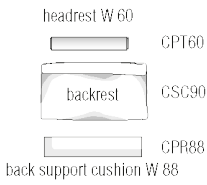

back cushion

W 75 - 29 1/2"

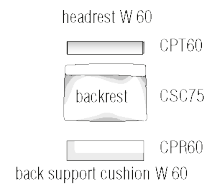

back cushion

W 75 - 29 1/2"

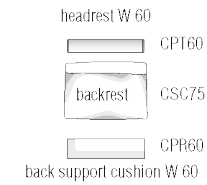

ornamental cushion

PCU90/75

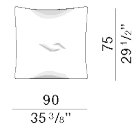

ornamental cushion

PCU90/75

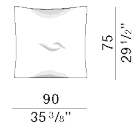

back cushion

W 105 - 41 3/8"

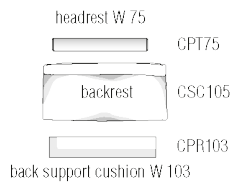

back cushion

W 90 - 35 3/8"

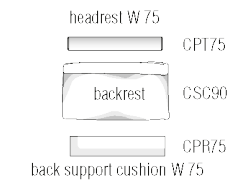

ornamental cushion

PCU90/75

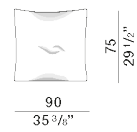

back cushion

W 120 - 47 1/4"

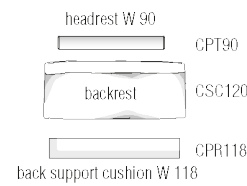

back cushion

W 105 - 41 3/8"

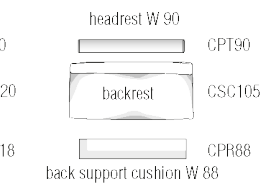

DATASHEET

REGISTERED
DESIGN

IX.2021

DIMENSIONS

corner shelf

AME2

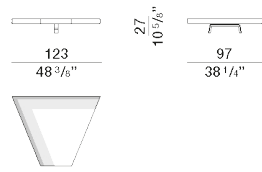

Molteni & C

trinket tray

AVP1

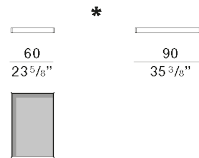

trinket tray

AVP2

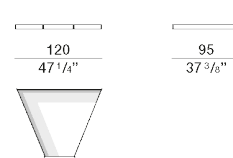

9

9

DATASHEET

REGISTERED
DESIGN

IX.2021

moltenigroup.com

Dimensions in centimeters and inches. The right to discontinue and make changes is reserved. This information is based on the latest product information available at the time of printing.

DOMINO NEXT — NICOLA GALLIZIA 2016

1—
3



In his search for stylized forms and characterful materials, Nicola Gallizia develops a series of versatile and complementary units that can fit into each other or be set side by side, such as small oval tables and poufs. They are made using and alternating steel, wood, stone, textiles and leather. Color, matter and form are the inspiration and the synthesis of the collection.

Wallpaper* Design Award 2017 | Best colada parlour



This symbol shows that the product has removable upholstery. Only qualified personnel can remove the upholstery of some of our products. If this information is pertinent, it will be included in the warnings section.



This symbol shows that the product is available on request in a fire resistant version that complies with the standards BS 5852 and TB 117-2013.

The buyer is responsible for checking to make sure that the product is suitable and compliant with the requirements for the designated use and the current applicable laws and standards for the destination and use of the product.

DATASHEET

REGISTERED
DESIGN

IX.2021

FINISHES

SMALL TABLES STRUCTURE FINISHES

black chrome
pewter colour

MARBLE SMALL TABLES

TOP FINISHES

white Carrara
emperador dark
green alpine
orient grey
silver wave
black marquina
silver dune
Sahara noir
calacatta gold

WOODEN SMALL TABLES

TOP FINISHES

eucalyptus
grey oak
graphite oak
walnut

GLASS TOP FINISHES

coloured glass
in the Molteni colour range
etched coloured glass
in the Molteni colour range

TECHNICAL INFORMATION

SMALL TABLES STRUCTURE (CHROME AND/OR PAINTED VERSIONS)

Steel with non-slip plastic feet.

WOODEN TOP

Wooden particleboard faced with Eucalyptus (*Eucalyptus globulus*), Oak (*Quercus*) or Walnut (*Juglans nigra*) veneer painted in colours from the "Molteni Range".

MARBLE TOP

Marble in Range finishes with anti-stain, water-repellent treatments.

GLASS TOP

Glass (th. 10mm), tempered coloured extralight or etched and coloured in the colours available in the "Molteni Range".

POUF

Solid firwood (*Picea abies*) and plywood frame, padded with foam polyurethane in various densities. Light velvet cover and plastic feet.

OUTER COVERING

See card attached, specific to each cover.



LEATHER VERSION
NOT REMOVABLE



AVAILABLE IN FIRE-RESISTANT
VERSION TB117 AND BS5852

SMALL TABLES

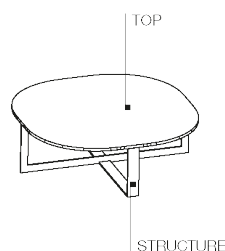

POUF

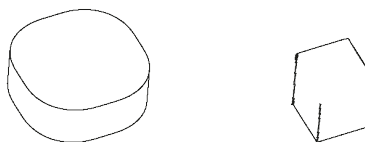

DATASHEET

REGISTERED
DESIGN

IX.2021

moltenigroup.com

Dimensions in centimeters and inches. The right to discontinue and make changes is reserved. This information is based on the latest product information available at the time of printing

DIMENSIONS

small tables

DTA1

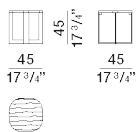

DTA2

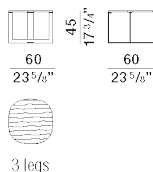

DTA3

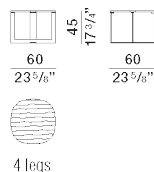

Molteni & C

small tables

DTA4

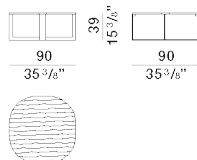

DTA5

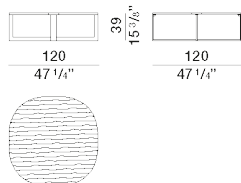

DTA6

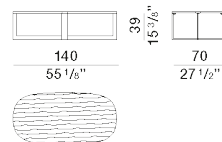

3 —

3

pouf

DPU01

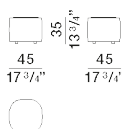

DPU02

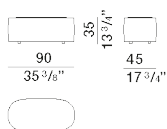

DPU03

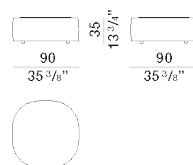

pouf

DPU04

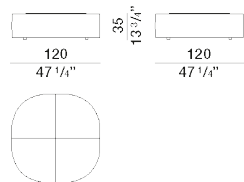

DPU05

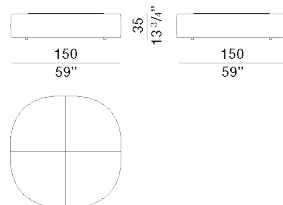

pouf

DPU11

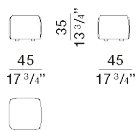

DPU12

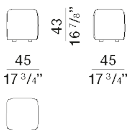

DATASHEET

REGISTERED
DESIGN

IX.2021

CORMO

This robust 4-ply rib gives a lively look and is produced from the highest quality undyed wool of which 70% New Zealand wool, that's why it feels soft and luxurious. On the floor this carpet delivers in both texture and pattern.

The natural colours make this carpet perfect for any home or office.

Available in 5 representative colours.

Specifications

Construction:	Loop rib
Material:	100% undyed wool (70% NZ wool)
Pile weight:	1240 gr/m ²
Backing:	SBR free Actionbac®
Width:	400 cm/ 500 cm
Suitability:	22 general domestic/ light project use
Thermal resistance:	0,14 m ² K/W (TOG rating 1.4)

Features and benefits



Support

 [Maintenance](#)

 [General fitting instructions](#)

NEW

OBLIQUE FLOOR

DESIGNED BY VINCENT VAN DUYSSEN



LIGHT SOURCE

TOP LED
8W
750 lm
2700K/CRI 90
800 lm
3000K/CRI 90
850 lm
4000K/CRI 90

DY Bianco Opaco
DY Matte White

AH Grigio Lucido
AH Gloss Grey

DX Ruggine Opaco
DX Matte Rust

DW Marrone Opaco
DW Matte Brown

DR Antracite Opaco
DR Matte Anthracite

DV Salvia Lucida
DV Gloss Salvia

**Descrizione**

Apparecchio di illuminazione a piedistallo con illuminazione diretta asimmetrica e supporto da pavimento. Accensione della lampada e regolazione dell'intensità della luce mediante interazione tattile. Corpo in alluminio fuso. Testata in alluminio fuso con lente full cut-off asimmetrica e integrata in metacrilato stampato ad iniezione. La struttura consta di un tubo in lega di alluminio estruso, lavorato meccanicamente. Fonte d'illuminazione LED completamente invisibile che garantisce il massimo confort visuale senza dover ricorrere a diaframmi o ad accessori antiabbaglianti che limitando le prestazioni dell'apparecchio. La speciale unità ottica, patentata, supera gli abituali standard di illuminazione per un interno residenziale, di lavoro e di studio, con una notevole protezione contro l'abbagliamento e con una illuminazione di qualità straordinaria.

Unità di Alimentazione

Trasformatore elettronico 100-240V - 50/60Hz.

Informazioni Aggiuntive

Grado di protezione IP20.
Classe di isolamento III.

Conformità e Marchi di Qualità

Apparecchio conforme alla Normativa Tecnica Europea EN60598-1 e relative parti seconde.

Description

Floor lamp with asymmetrical direct lighting and floor stand. Haptic interaction for switching and dimming. Cast aluminum body. Cast aluminum head with integrated full cut-off asymmetric lens in injection molded methacrylate. Structure made of a mechanically worked extruded aluminum alloy tube. Completely invisible LED sources for maximum visual comfort without the need for diaphragms or anti-glare accessories that limit the performance of the luminaire. The patented special optical unit exceeds the usual lighting standards for applications in residential, work and study environments with high glare protection and outstanding light quality.

Power Supply

100-240 V - 50/60 Hz electronic transformer.

Additional Information

IP20 protection grade.
Insulation class III.

Standard Compliance and Quality Marks

EN60598-1 European Technical Standards and any subsequent additions.

OBLIQUE FLOOR

Oblique Floor

Light Source: Top LED 8W - 24V - 750 lm - 2700K/CRI 90 / 8W - 24V - 800 lm - 3000K/CRI 90 / 8W - 24V - 850 lm - 4000K/CRI 90

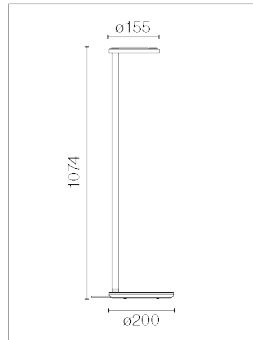

Apparecchio di illuminazione a piedistallo che, grazie alla sua originale lente patentata, offre sia una distribuzione luminosa asimmetrica sia un confort visuale eccellente. La sua forma, la sua altezza e le sue dimensioni concordano con la funzionalità del prodotto, che proporziona un'eccellente illuminazione da lettura o da accompagnamento rimanendo la fonte luminosa nascosta alla vista dell'utente.
Driver input: 24 V

Floor lamp that, thanks to its innovative patented lens, offers asymmetrical light distribution and excellent visual comfort. Its shape, height and dimensions are consistent with the functionality of the product, which provides excellent reading or companion lighting while keeping the light source invisible to the user.
Driver input: 24 V

2700K

- 09.8220.DY
- 09.8220.AH
- 09.8220.DX
- 09.8220.DW
- 09.8220.DR
- 09.8220.DV

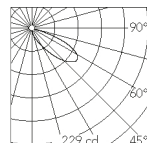

Beam Angle: 35°		
h(m)	E(lx)	D(m)
1	229	2.18
2	57	4.36
3	25	6.54
4	14	8.72
5	9	10.90

Luminous flux, luminaire
479 lm

4000K

- 09.8222.DY
- 09.8222.AH
- 09.8222.DX
- 09.8222.DW
- 09.8222.DR
- 09.8222.DV

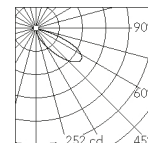

Beam Angle: 35°		
h(m)	E(lx)	D(m)
1	252	2.18
2	63	4.36
3	28	6.54
4	16	8.72
5	10	10.90

Luminous flux, luminaire
525 lm

3000K

- 09.8221.DY
- 09.8221.AH
- 09.8221.DX
- 09.8221.DW
- 09.8221.DR
- 09.8221.DV

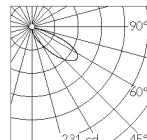

Beam Angle: 35°		
h(m)	E(lx)	D(m)
1	231	2.18
2	58	4.36
3	26	6.54
4	14	8.72
5	9	10.90

Luminous flux, luminaire
482 lm

Oblique Floor USB-C

Light Source: Top LED 8W - 24V - 750 lm - 2700K/CRI 90 / 8W - 24V - 800 lm - 3000K/CRI 90 / 8W - 24V - 850 lm - 4000K/CRI 90

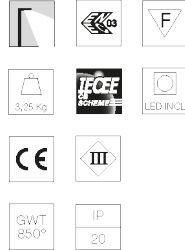
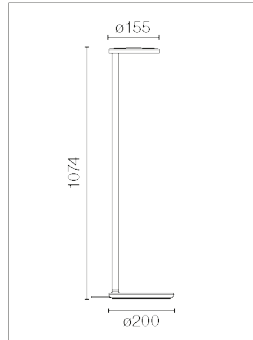

Apparecchio di illuminazione a piedistallo che, grazie alla sua originale lente patentata, offre sia una distribuzione luminosa asimmetrica sia un confort visuale eccellente. La sua forma, la sua altezza e le sue dimensioni concordano con la funzionalità del prodotto, che proporziona un'eccellente illuminazione da lettura o da accompagnamento rimanendo la fonte luminosa nascosta alla vista dell'utente. Modello con sistema USB-C per la ricarica del cellulare inserito nel piedistallo.
Driver input: 24 V

Floor lamp that, thanks to its innovative patented lens, offers asymmetrical light distribution and excellent visual comfort. Its shape, height and dimensions are consistent with the functionality of the product, which provides excellent reading or companion lighting while keeping the light source invisible to the user. Model with USB-C mobile charging in its base.
Driver input: 24 V

2700K

- 09.8230.DY
- 09.8230.AH
- 09.8230.DX
- 09.8230.DW
- 09.8230.DR
- 09.8230.DV

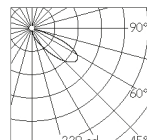

Beam Angle: 35°		
h(m)	E(lx)	D(m)
1	229	2.18
2	57	4.36
3	25	6.54
4	14	8.72
5	9	10.90

Luminous flux, luminaire
479 lm

4000K

- 09.8232.DY
- 09.8232.AH
- 09.8232.DX
- 09.8232.DW
- 09.8232.DR
- 09.8232.DV

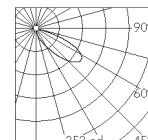

Beam Angle: 35°		
h(m)	E(lx)	D(m)
1	252	2.18
2	63	4.36
3	28	6.54
4	16	8.72
5	10	10.90

Luminous flux, luminaire
525 lm

3000K

- 09.8231.DY
- 09.8231.AH
- 09.8231.DX
- 09.8231.DW
- 09.8231.DR
- 09.8231.DV

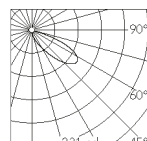

Beam Angle: 35°		
h(m)	E(lx)	D(m)
1	231	2.18
2	58	4.36
3	26	6.54
4	14	8.72
5	9	10.90

Luminous flux, luminaire
482 lm

Colchão Confort-Visco

Propiedades

- Acolhida gradual do corpo durante o descanso
- Melhora da circulação sanguínea
- Independência de leitos
- Libera as pressões no descanso
- Facilita a descontracturação muscular

Características

- Firmeza intermédia-alta
- Acolchoado com volume facilitando a acolhida do corpo
- Núcleo suave de poliuretano que diminui a pressão exercida sobre o corpo
- Alças laterais para maior comodidade
- Design moderno com linhas simples e elegantes
- Fabricado em Espanha
- Gran ergonómia e recuperação

Sommier Revestido Redondo Tampo Liso

Um espaço de armazenamento extra para o quarto que representa uma excelente base para o descanso que irá proporcionar firmeza extra.

O sommier redondo de Maxcolchon é feito de estrutura metálica rija de tubo de aço e forrado com tecido 3D na tampa e pele sintética em sua base. Inclui borracha perimetral, diretamente apoiado no chão e evitando a deterioração da nossa equipe de descanso.

Nas medidas, 80, 90, 100, 105, 110 e 120 o sommier rebatível revestido é inteiro, nas medidas 135, 140 e 150 o sommier rebatível revestido vai partido horizontalmente para facilitar o acesso à morada. As medidas de 160, 180 e 200 unem dois sommier rebatíveis com placas de união, resultando assim um sommier rebatível partido vertical.

- Abertura: Frontal
- Tampa: Tecido **3D cinza**
- Cajón: pele sintética **bege, branco, preto ou chocolate**
- Altura total: 35 cm
- Altura gaveta exterior: 30 cm
- Altura gaveta interior: 26 cm
- Borracha perimetral para apoio direto ao chão

Tapa superior



- É rijo e de estrutura metalizada
- Forro en tecido 3D
- Abertura frontal con asa de madeira
- Topes metálicos: Atuam como sujeita-colchões e evitam qualquer deslocamento do colchão ao abrir o tampo

Gaveta



- Estructura interior de tubo de aço
- Grande resistência.
- Altura interior da caixa 24 cm
- Altura total do sommier 34 cm (incluidos caixa e tampo)
- Grande capacidade de arrumação

Fundo do sommier



- Tabuleiro de madeira depositado no interior do Sommier
- Evita que os objetos colocados se danifiquem

Ferragens e hidráulicos



- Conjunto de peças necessários para abrir e fechar o tampo

Almofada viscoelástica

O complemento perfeito para um bom descanso é nossa almofada viscoelástica, que ajuda a eliminar pressões e os problemas cervicais favorecendo um descanso confortável para nossas cervicais.

A almofada viscoelástica de Maxcolchon é fabricada como capa de tecido stretch que fornece elasticidade e melhora os movimentos e tencel favorecendo a transpirabilidade de nossa almofada, ajudando a eliminar os microdespetares.

Características

- Capa interior malhada
- Capa exterior com zipper em tecido stretch e tencel
- Máxima adaptabilidade e ergonomia
- Se apresenta em uma prática bolsa com alça

As medidas 80, 90 100, 105, 110, 120 e 135 incluem uma almofada. As medidas de 140, 150, 160, 180 e 200 incluem duas almofadas partidas

Em função da largura do colchão, serão incluídas uma ou duas almofadas de medidas standard de almofadas equivalentes. Para cama de 80, almofada de 80 cm. Para cama de 90, almofada de 90 cm. Para as medidas de colchão 100, 105, 110 e 120 se incluirá uma almofada de 105 cm. Para camas de 135 uma almofada de 135. Para cama de 140 duas almofadas de 70 cm. Para cama de 150 duas almofadas de 75 cm. Para a medida de 160 incluem-se duas almofadas de 80 cm, e para as medidas de colchão de 180 e 200 duas almofadas de 90 cm.

Largura do colchão	80	90	100	105	110	120	135	140	150	160	180	200
Unidades	1	1	1	1	1	1	2	2	2	2	2	2
Medida da almofada	80x35	90x35	90x35	105x35	105x35	105x35	70x35	70x35	75x35	75x35	90x35	90x35

GLOVE-UP — PATRICIA URQUIOLA 2016

1—
2



Glove-Up is the evolution of a rigorous design theme, featuring sinuous, moulded and softly linked lines. A balance of forms which, from the fluid line of the backrest, flows into the lightness of the legs. An inviting chair or small armchair, upholstered in fabric or leather, make Glove-Up fun and versatile, suitable for any classic or contemporary setting.



This symbol shows that the product has removable upholstery. Only qualified personnel can remove the upholstery of some of our products. If this information is pertinent, it will be included in the warnings section.



This symbol shows that the product is available on request in a fire resistant version that complies with the standards BS 5852 and TB 117-2013.

The buyer is responsible for checking to make sure that the product is suitable and compliant with the requirements for the designated use and the current applicable laws and standards for the destination and use of the product.

DATASHEET

REGISTERED
DESIGN

IX.2021

TECHNICAL INFORMATION

INTERNAL STRUCTURE
Metal frame with elastic straps.

STRUCTURE PADDING
Flexible cold-foamed polyurethane. Matching light velvet cover with resin.

FEET
Plastic material.

REMOVABLE OUTER COVERS
(See attached card, specific for each cover).

Molteni&C



AVAILABLE IN FIRE-RESISTANT
VERSION TB117 AND BS6662

2 —
2

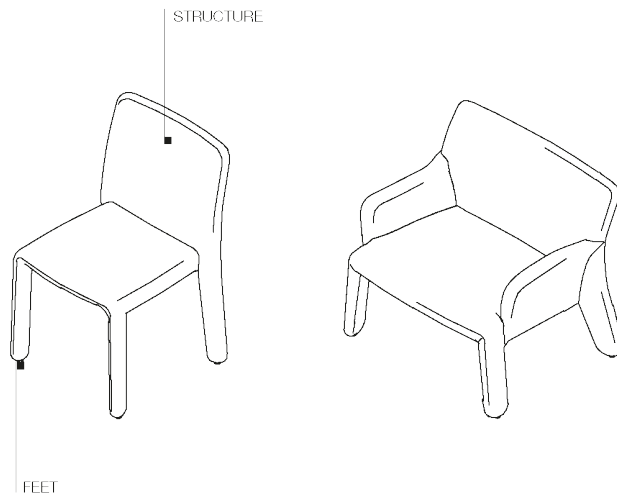

DIMENSIONS

chair
GSD1

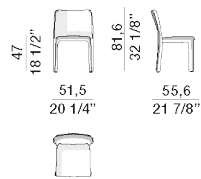

armchair
GPL1

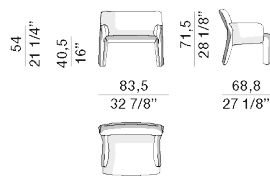

code	gross weight kg.	volume mc.	packages	code	gross weight kg.	volume mc.	packages
GPL1	20	0,485	1	GSD1	9	0,29	1

DATASHEET

REGISTERED
DESIGN

IX.2021

moltenigroup.com

Dimensions in centimeters and inches. The right to discontinue and make changes is reserved. This information is based on the latest product information available at the time of printing.

Buds 3, sospensione

by Rodolfo Dordoni

FOSCARINI



DESCRIPTION

In the 1990s, Rodolfo Dordoni designed a collection of table, floor and suspension lamps for Foscarini in brightly coloured blown glass, named after the natural elements: Fruits, Blossom and Buds. Today Buds has been restyled again, interpreting contemporary taste with a sophisticated wealth and focus on materials. the star of the design remains blown glass, with a five-layer hand-crafted process, which is immediately evident thanks to the larger cut of the diffuser. With the new range of colours - cold brown, cold grey, bamboo green and white, with a straw-yellow internal finish- Buds takes on a dual value: it is warm when the lamp is on and cold when off.

MATERIALS

Blown satin glass

COLORS

Warm White, Bamboo Green

Buds 3, sospensione

technical details

FOSCARINI

Suspension lamp with diffused light and down . Handblown cased glass diffuser, white on the inside and colored on the outside, with glossy finish. With the straw-yellow interior, the "warm white" version appears ivory in hue when the lamp is on and it remains white when off. Transparent injection moulded polycarbonate diffuser support. Stainless steel suspension cable and a transparent electrical cable. ABS glossy white canopy. Canopy decentralisation kit available.

Buds 3

SCHEMATIC & LIGHT EMISSION



MATERIAL

Blown satin glass

COLORS



ACCESSORIES

Round multiple canopy
Linear multiple canopy 90 cm
Linear multiple canopy 135 cm
Kit B
Kit F
Kit M

LIGHT SOURCE

LED retrofit included
21WE27
2700 K 2500 lm CRI>80
Dimmable with TRIAC technology

CERTIFICATIONS



ENERGY EFFICIENCY

A+

Buds 3, sospensione

technical details

FOSCARINI

Buds 3 MyLight

SCHEMATIC & LIGHT EMISSION



MATERIAL

Blown satin glass

COLORS



ACCESSORIES

Round multiple canopy
Linear multiple canopy 90 cm
Linear multiple canopy 135 cm
Kit B
Kit F
Kit M

LIGHT SOURCE

LED retrofit included
21WE27
2700 K 2500 lm CRI>80
Dimmable via Bluetooth with Casambi App

CERTIFICATIONS



ENERGY EFFICIENCY

A+

Buds 3 LED

SCHEMATIC & LIGHT EMISSION



MATERIAL

Blown satin glass

COLORS



ACCESSORIES

Kit B

LIGHT SOURCE

LED included
24W COB
2700 K 2581 lm CRI>90
Dimmable

CERTIFICATIONS



ENERGY EFFICIENCY

A+

Buds 3, sospensione

Designer

FOSCARINI

RODOLFO DORDONI

With an array of activities ranging from architecture, to product design, artistic direction, and the setting up of showrooms and exhibitions, Rodolfo Dordoni has put his name to some of the most significant and famous Italian design projects, including Lumiere:

a contemporary restyling of the classic bedside lamp, made in blown glass and die-cast metal, which has become one of the biggest successes in the Foscarini collection. Again in blown glass, a material capable of conveying emotions of timeless beauty, is the Buds collection.



Buds 3, sospensione
family

FOSCARINI



Buds 2



Buds 2



Buds 3



Buds 1



Buds 1

MILANO 1932



PANGEN

Historical Archive, 2012

This lampshade is a fluid, minimal dome shape, its lacquer finish and modern colors ensuring surprising lighting. Available in suspension and ceiling mounted versions.

Ceiling lamp with direct and dimmable light. Top diffuser made of painted metal. Bottom diffuser made of opaline polycarbonate. Chromed metal wall bracket. Bulb not included.

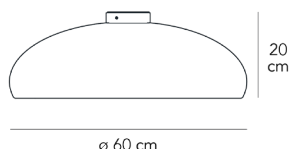

MADE IN

IT

DIMMER

Dimmable

CERTIFICATIONS

CE **EAC** **IP20**

COLOR



MATERIAL DESCRIPTION

polymer, metal

COLOR DESCRIPTION SKU

white

GROUP TENSION

Bulb

ENERGY CLASS

A G

LIGHT SOURCE

3x max 46W E27

Ci riserviamo il diritto di modificare le specifiche del nostro prodotto. Per le ultime informazioni visita il sito www.fontanaarte.com o contattaci all'indirizzo ccare.ecommerce@fontanaarte.com

HONESTY

Fall in love with our new soft product Honesty. A uniquely rich textured polyamide carpet with a luxurious appearance and a superb underfoot feel.

This elegant style of carpet is available in 12 fashionable colours and a perfect choice for commercial and residential use.



Specifications

Construction:	Luxury matt saxony
Yarn content:	100% PA 6.6
Pile weight:	2075 gr/m ²
Backing:	SBR free Starback
Width:	400 cm
Suitability:	23 heavy domestic use / 33 heavy contract use
Thermal resistance:	0.17 m ² K/W

Features and benefits



Support

-  [Maintenance](#)
-  [General fitting instructions](#)

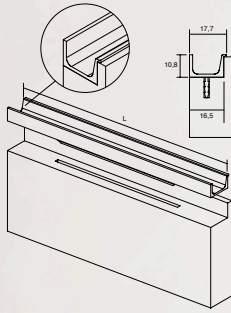

24

Stainless steel look	L	mm
0163147L24	147	15
0163197L24	197	15
0163247L24	247	15
0163297L24	297	15
0163347L24	347	15
0163397L24	397	15
0163447L24	447	10
0163497L24	497	10
0163597L24	597	10
0163697L24	697	10
0163797L24	797	10
0163897L24	897	5
0163997L24	997	5
01631197L24	1197	5

JEY2 0163
(above/arrriba)

JEY 0127
(abajo/below)

Design: Viefel® Team

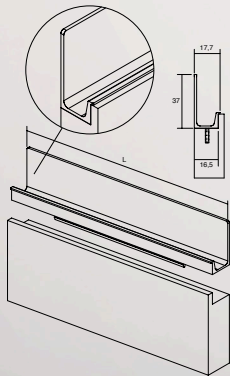

24

Stainless steel look	L	mm
0127147L24	147	15
0127197L24	197	15
0127247L24	247	15
0127297L24	297	15
0127347L24	347	15
0127397L24	397	15
0127447L24	447	10
0127497L24	497	10
0127597L24	597	10
0127697L24	697	10
0127797L24	797	10
0127897L24	897	5
0127997L24	997	5
01271197L24	1197	5

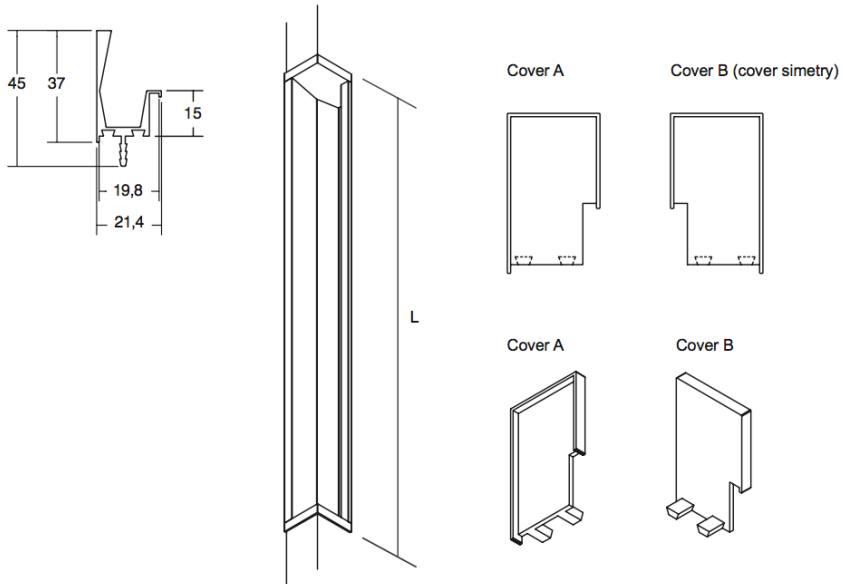

M1	M2	M23	M41	L		
Matt white Blanco mate	Matt black Negro mate	Metallic grey Gris metal	Metallic brown Marrón metal			
0449200LM1	0449200LM2	0449200LM23	0449200LM41	200	25	ALUMINIUM
0449350LM1	0449350LM2	0449350LM23	0449350LM41	350	25	ALUMINIUM
04491100LM1	04491100LM2	04491100LM23	04491100LM41	1100	15	ALUMINIUM
04493000LM1	04493000LM2	04493000LM23	04493000LM41	3000	10	ALUMINIUM
0449035ZM1A	0449035ZM2A	0449035ZM23A	0449035ZM41A	-	25	ZAMAK
0449035ZM1B	0449035ZM2B	0449035ZM23B	0449035ZM41B	-	25	ZAMAK

Descrição

Esta sanita sem rebordo, com um design único e intemporal, consegue facilmente valorizar qualquer casa de banho. Esta sanita com função de descarga sem rebordo possui uma superfície de cerâmica particularmente durável e fácil de cuidar, o que simplifica a limpeza e garante uma utilização a longo prazo.

O assento da sanita com mecanismo de fecho automático suave evita que a tampa da sanita caia. O aumento de + 7 cm proporciona um conforto de assento especial, especialmente para pessoas altas e idosos. Esta sanita é fácil de montar.

A entrega inclui acessórios de montagem

Especificações

- Cor: preto
- Material: cerâmica
- Dimensões com tampa: 50,5 x 36,5 x 50 cm (C x L x A)
- Dimensões sem tampa: 48 x 36,5 x 45,5 cm (C x L x A)
- Elevada: + 7 cm
- Sem rebordo - para uma melhor higiene
- Assento com função de fecho suave
- Remoção da sujidade
- Adequada para pessoas mais velhas ou altas
- Montagem necessária: sim
- EAN:8720286021019
- SKU:145780
- Brand:vidaXL

vidaXL Sanita alta sem rebordo fecho suave cerâmica preto

Marca: vidaXL

Vendedor: vidaXL

Cor



211.99 €

Incl. IVA

 **Eu quero**

 Neste momento o artigo não está disponível

 Entrega e devolução gratuitas

 Tempo de entrega: 3-5 dias úteis ⓘ

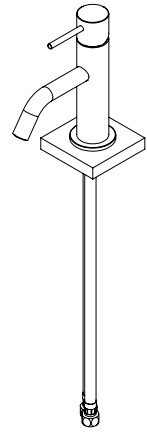
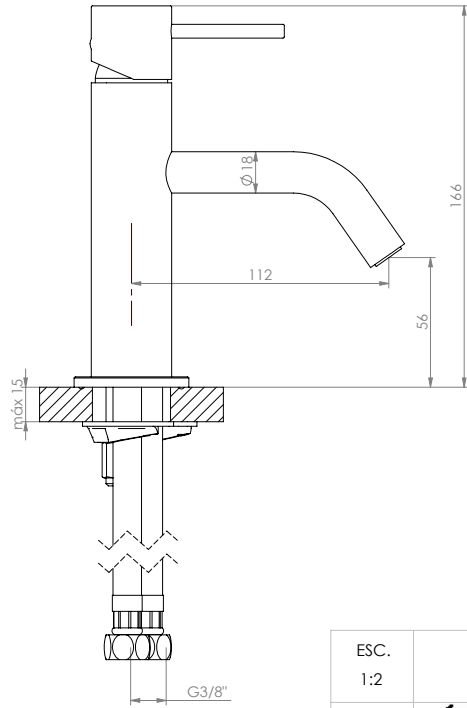
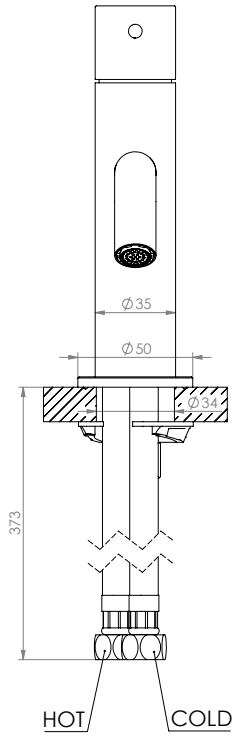

ESC. 1:2	Monocomando Lavatório	
02/12/2021	 ASM TAPS WATER SOUL	SLIMASM010



Axis 0000603

Combino

□ 537mm □ 250mm △ 150mm

Os nossos acessórios podem ser fabricados sob medida e em diversos acabamentos. Por favor consulte-nos